



Output Compare with Dedicated Timer

HIGHLIGHTS

This section of the manual contains the following topics:

1.0	Introduction	2
2.0	Output Compare Registers	4
3.0	Modes of Operation	11
4.0	Output Compare Operation with DMA	39
5.0	Output Compare Operation in Power-Saving States	40
6.0	I/O Pin Control	41
7.0	Register Maps	42
8.0	Design Tips	43
9.0	Related Application Notes	44
10.0	Revision History	45

dsPIC33/PIC24 Family Reference Manual

Note: This family reference manual section is meant to serve as a complement to device data sheets. Depending on the device variant, this manual section may not apply to all dsPIC33/PIC24 devices.

Please consult the note at the beginning of the “**Output Compare with Dedicated Timer**” chapter in the specific device data sheet to check whether this document supports the device you are using.

Device data sheets and family reference manual sections are available for download from the Microchip Worldwide Web site at: <http://www.microchip.com>.

This document supersedes the following PIC24 and dsPIC33 Family Reference Manual sections:

DS Number	Section Number	Title
DS39723B	35	Output Compare with Dedicated Timer
DS70358	13	Output Compare

1.0 INTRODUCTION

The Output Compare (OC) module in dsPIC33/PIC24 devices compares the Output Compare Timer register value with the value of one or two Compare registers, depending on its mode of operation. The OC module on compare match events can generate a single output transition or a series of output pulses. Like most PIC[®] MCU peripherals, the OC module can also generate interrupts on a compare match event.

Each Output Compare timer can use one of the available six selectable time clocks. The clock is selected using the Output Compare x Clock Select (OCTSEL<2:0>) bits in the Output Compare x Control Register 1 (OCxCON1<12:10>). For more information on specific timers that can be used as a time base for the Output Compare timer, refer to the specific device data sheet.

Figure 1-1 shows the block diagram of the OC module.

Note: For more information on the number of available Output Compare channels, refer to the specific device data sheet.

All of the Output Compare channels are functionally identical. In this section, an ‘x’ in the pin, register or bit name denotes the specific Output Compare channel.

The OCx output must be assigned to an available RPN pin before use if the device supports Peripheral Pin Select (PPS). For more information, refer to the “**Peripheral Pin Select (PPS)**” section in the specific device data sheet.

Output Compare with Dedicated Timer

Figure 1-1: Output Compare x Module Block Diagram (Double-Buffered, 16-Bit PWM Mode)

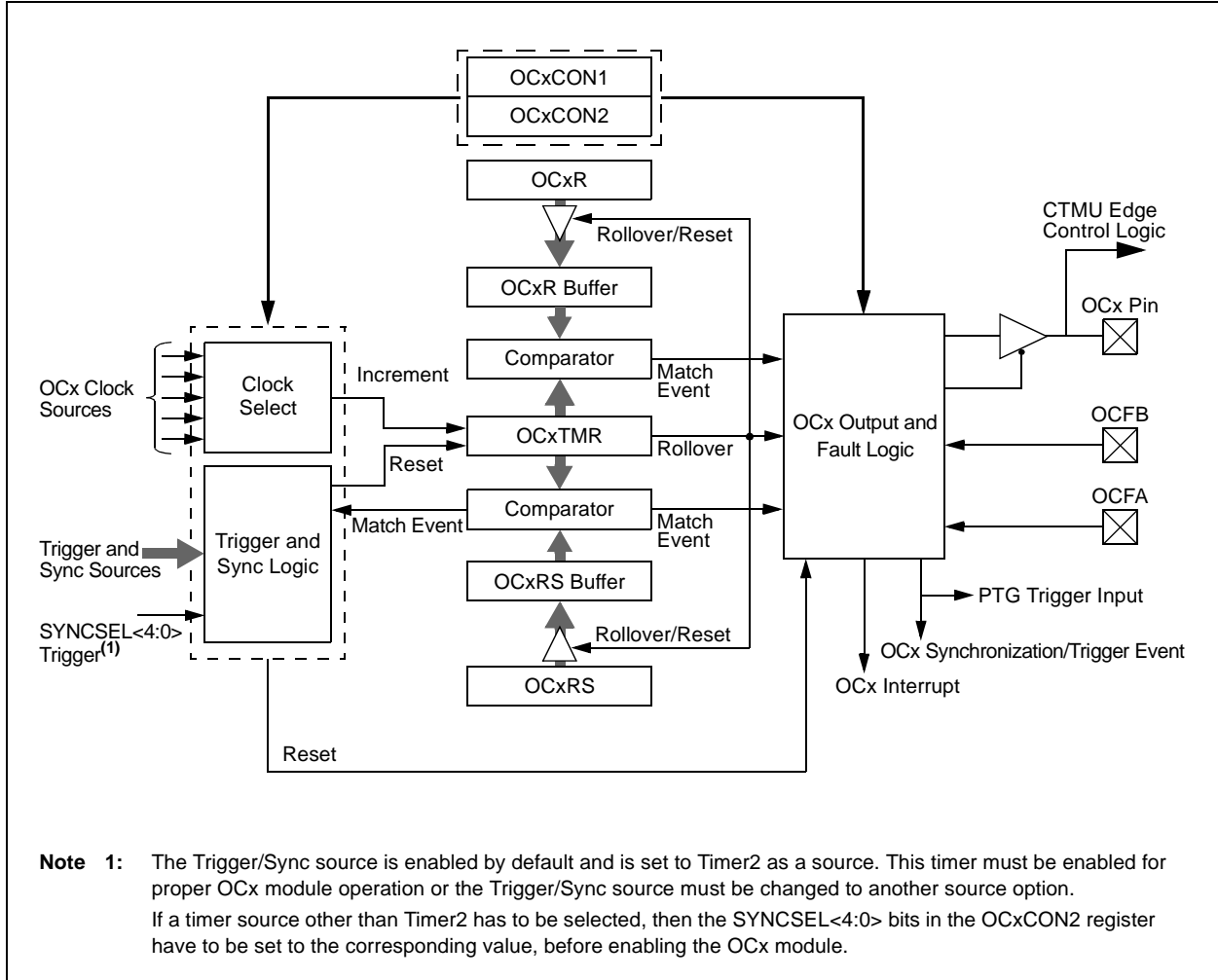

dsPIC33/PIC24 Family Reference Manual

2.0 OUTPUT COMPARE REGISTERS

Note: Each dsPIC33/PIC24 family device variant may have one or more Output Compare with Dedicated Timer modules. An 'x' used in the names of pins, control/status bits and registers denote the particular Output Compare channel number. Refer to the “**Output Compare with Dedicated Timer**” chapter in the specific device data sheet for more details.

This section outlines the specific functions of each register that controls the operation of the Output Compare with Dedicated Timer module. The registers are as follows:

- **OCxCON1: Output Compare x Control Register 1** and **OCxCON2: Output Compare x Control Register 2(4)**

These are the OCx Control registers for the Output Compare channel.

- **OCxR: Output Compare x Register**

This is the OCx Data register for the Output Compare channel.

- **OCxRS: Output Compare x Secondary Register**

This is the OCx Secondary Data register for the Output Compare channel.

- **OCxTMR: Output Compare x Timer Register**

This is the OCx Internal Time Base register for the Output Compare channel.

All of the control registers have identical bit definitions and are represented by common register definitions as listed in [Register 2-1](#) to [Register 2-5](#).

Output Compare with Dedicated Timer

Register 2-1: OCxCON1: Output Compare x Control Register 1

U-0	U-0	R/W-0	R/W-0	R/W-0	R/W-0	R/W-0	R/W-0
—	—	OCSIDL	OCTSEL2	OCTSEL1	OCTSEL0	ENFLT2/ ENFLTC ⁽³⁾	ENFLT1/ ENFLTB ⁽³⁾
bit 15						bit 8	

R/W-0	R/W-0, HCS	R/W-0, HCS	R/W-0, HCS	R/W-0	R/W-0	R/W-0	R/W-0
ENFLT0/ ENFLTA	OCFLT2/ OCFLTC ⁽³⁾	OCFLT1/ OCFLTB ⁽³⁾	OCFLT0/ OCFLTA	TRIGMODE	OCM2 ⁽¹⁾	OCM1 ⁽¹⁾	OCM0 ⁽¹⁾
bit 7						bit 0	

Legend:	HCS = Hardware Clearable/Settable bit		
R = Readable bit	W = Writable bit	U = Unimplemented bit, read as '0'	
-n = Value at POR	'1' = Bit is set	'0' = Bit is cleared	x = Bit is unknown

bit 15-14 **Unimplemented:** Read as '0'

bit 13 **OCSIDL:** Output Compare x Stop in Idle Mode Control bit
 1 = Output Compare x halts in CPU Idle mode
 0 = Output Compare x continues to operate in CPU Idle mode

bit 12-10 **OCTSEL<2:0>:** Output Compare x Clock Select bits
 111 = Peripheral clock (FCY)
 110 = Reserved
 101 = Reserved for PTGOx⁽⁴⁾
 100 = Timer1 clock (only the synchronous clock is supported)
 011 = Timer5 clock
 010 = Timer4 clock
 001 = Timer3 clock
 000 = Timer2 clock

bit 9 **ENFLT2/ENFLTC:** Fault 2/C Input Enable bit⁽³⁾
 1 = Fault inputs are enabled
 0 = Fault inputs are disabled

bit 8 **ENFLT1/ENFLTB:** Fault 1/B Input Enable bit⁽³⁾
 1 = Fault inputs are enabled
 0 = Fault inputs are disabled

bit 7 **ENFLT0/ENFLTA:** Fault 0/A Input Enable bit (corresponds to the OCFA pin)
 1 = Fault inputs are enabled
 0 = Fault inputs are disabled

bit 6 **OCFLT2/OCFLTC:** Output Compare x PWM Fault 2/C Condition Status bit⁽³⁾
 1 = PWM Fault condition has occurred
 0 = PWM Fault condition has not occurred

bit 5 **OCFLT1/OCFLTB:** Output Compare x PWM Fault 1/B Condition Status bit⁽³⁾
 1 = PWM Fault condition has occurred
 0 = PWM Fault condition has not occurred

- Note 1:** The OCx output must also be configured to an available RPn pin if the device supports Peripheral Pin Select (PPS). For more information, refer to the specific device data sheet.
- 2:** The OCxR and OCxRS registers are double-buffered only in PWM modes.
- 3:** Refer to the specific device data sheet to find the Fault bits mapping.
- 4:** This mode is not available on all devices. Refer to the "Output Compare" chapter of the specific device data sheet.

dsPIC33/PIC24 Family Reference Manual

Register 2-1: OCxCON1: Output Compare x Control Register 1 (Continued)

- bit 4 **OCFLT0/OCFLTA:** Output Compare x PWM Fault 0/A Condition Status bit
1 = PWM Fault condition has occurred
0 = PWM Fault condition has not occurred
- bit 3 **TRIGMODE:** Trigger Status Mode Select bit
1 = TRIGSTAT (OCxCON2<6>) bit is cleared when OCxRS = OCxTMR or in software
0 = TRIGSTAT (OCxCON2<6>) bit is cleared only by software
- bit 2-0 **OCM<2:0>:** Output Compare x Mode Select bits⁽¹⁾
111 = Center-Aligned PWM mode: Output is set high when OCxTMR = OCxR and is set low when OCxTMR = OCxRS⁽²⁾
110 = Edge-Aligned PWM mode: Output is set high when OCxTMR = 0 and is set low when OCxTMR = OCxR⁽²⁾
101 = Double Compare Continuous Pulse mode: Initializes the OCx pin low and toggles the OCx state continuously on alternate matches of OCxR and OCxRS
100 = Double Compare Single-Shot mode: Initializes the OCx pin low and toggles the OCx state on matches of OCxR and OCxRS for one cycle
011 = Single Compare mode: Compares events with OCxR and continuously toggles the OCx pin
010 = Single Compare Single-Shot mode: Initializes the OCx pin high, compares event with OCxR and forces OCx pin low
001 = Single Compare Single-Shot mode: Initializes the OCx pin low, compares event with OCxR and forces OCx pin high
000 = Output Compare channel is disabled

- Note 1:** The OCx output must also be configured to an available RPN pin if the device supports Peripheral Pin Select (PPS). For more information, refer to the specific device data sheet.
- 2:** The OCxR and OCxRS registers are double-buffered only in PWM modes.
- 3:** Refer to the specific device data sheet to find the Fault bits mapping.
- 4:** This mode is not available on all devices. Refer to the “**Output Compare**” chapter of the specific device data sheet.

Output Compare with Dedicated Timer

Register 2-2: OCxCON2: Output Compare x Control Register 2⁽⁴⁾

R/W-0	R/W-0	R/W-0	R/W-0	U-0	R/W-0	R/W-0	R/W-0
FLTMD	FLTOUT	FLTTRIEN	OCINV	—	DCB1 ⁽³⁾	DCB0 ⁽³⁾	OC32
bit 15							bit 8

R/W-0	R/W-0, HS	R/W-0	R/W-0	R/W-0	R/W-0	R/W-0	R/W-0
OCTRIG	TRIGSTAT	OCTRIS	SYNCSEL4 ^(1,2,5)	SYNCSEL3 ^(1,2,5)	SYNCSEL2 ^(1,2,5)	SYNCSEL1 ^(1,2,5)	SYNCSEL0 ^(1,2,5)
bit 7							bit 0

Legend:	HS = Hardware Settable bit
R = Readable bit	W = Writable bit
U = Unimplemented bit, read as '0'	
-n = Value at POR	'1' = Bit is set
	'0' = Bit is cleared
	x = Bit is unknown

- bit 15 **FLTMD:** Fault Mode Select bit
 1 = Fault mode is maintained until the Fault source is removed; the corresponding OCFLTx bit is cleared in software and a new PWM period starts
 0 = Fault mode is maintained until the Fault source is removed and a new PWM period starts
- bit 14 **FLTOUT:** Fault Out bit
 1 = PWM output is driven high on a Fault
 0 = PWM output is driven low on a Fault
- bit 13 **FLTTRIEN:** Fault Output State Select bit
 1 = OCx pin is tri-stated on a Fault condition
 0 = OCx pin I/O state is defined by the FLTOUT bit on a Fault condition
- bit 12 **OCINV:** OCMP Invert bit
 1 = OCx output is inverted
 0 = OCx output is not inverted
- bit 11 **Unimplemented:** Read as '0'
- bit 10-9 **DCB<1:0>:** PWM Duty Cycle Least Significant bits⁽³⁾
 These bits can be considered as the two Least Significant bits (LSBs) of the duty cycle in the Pulse Generation modes. They are also used to delay the falling edge of the OCx output in all other modes and the rising edge when the output inversion is active (OCINV bit (OCxCON2<12>) = 1).
 00 = OCx output falling edge transitions on the rising edge of the P1 clock (Legacy mode)
 01 = OCx output falling edge transitions on the rising edge of the P2 clock
 10 = OCx output falling edge transitions on the rising edge of the P3 clock
 11 = OCx output falling edge transitions on the rising edge of the P4 clock
 The DCB<1:0> bits can be used to generate LSBs of the PWM with a resolution of Peripheral Clock/2.

- Note 1:** Never use an OCx (SYNCSEL<4:0> = 11111, selecting the same OCx module) module as a Trigger/Synchronization source when the OCTRIG bit = 1. The source selected by the SYNCSEL<4:0> bits must operate from the same clock source when the OCTRIG bit = 0. When OCTRIG = 1, the source selected by the SYNCSELx bits can be asynchronous. The trigger source needs to create an event pulse which will trigger the time base when a rising edge has been detected.
- 2:** The inputs, SYNCSEL<4:0> = Input Capture x (ICx), should only be used as trigger sources and not as Sync sources.
- 3:** The duty cycle Least Significant bits (DCB<1:0>) in the OCxCON2<10:9> register are double-buffered in PWM modes only (OCM<2:0> bits (OCxCON1<2:0>) = 111, 110). This feature is not implemented in all the devices; refer to the specific device data sheet for more information.
- 4:** These bits are not available on all devices; refer to the specific device data sheet for availability.
- 5:** When an Output Compare x module (OCx) is disabled, it sends a trigger out signal. If a second Output Compare y module (OCy) uses OCx as a Trigger or a Synchronization source, it must first deselect the OCx as its trigger source before OCx is disabled to avoid receiving an erroneous signal.

dsPIC33/PIC24 Family Reference Manual

Register 2-2: OCxCON2: Output Compare x Control Register 2⁽⁴⁾ (Continued)

bit 8 **OC32**: Cascade Two Output Compare x Modules Enable bit (32-bit operation)

- 1 = Cascade module operation is enabled
- 0 = Cascade module operation is disabled

bit 7 **OCTRIG**: Output Compare x Trigger/Sync Select bit

- 1 = Triggers the OCx from the source designated by the SYNCSELx bits
- 0 = Synchronizes the OCx with the source designated by the SYNCSELx bits

bit 6 **TRIGSTAT**: Timer Trigger Status bit

- 1 = Timer source has been triggered and is running
- 0 = Timer source has not been triggered and is being held clear

bit 5 **OCTRIS**: Output Compare x Output Pin Direction Select bit

- 1 = OCx is tri-stated
- 0 = OCx module drives the OCx pin

bit 4-0 **SYNCSEL<4:0>**: Trigger/Synchronization Source Selection bits^(1,2,5)

These bits select the CMPx, ADCx, ICx, OCx, PTGOx and Timerx inputs as Trigger/Synchronization sources. Refer to the “**Output Compare**” chapter in the specific device data sheet for availability.

- Note 1:** Never use an OCx (SYNCSEL<4:0> = 11111, selecting the same OCx module) module as a Trigger/Synchronization source when the OCTRIG bit = 1. The source selected by the SYNCSEL<4:0> bits must operate from the same clock source when the OCTRIG bit = 0. When OCTRIG = 1, the source selected by the SYNCSELx bits can be asynchronous. The trigger source needs to create an event pulse which will trigger the time base when a rising edge has been detected.
- 2:** The inputs, SYNCSEL<4:0> = Input Capture x (ICx), should only be used as trigger sources and not as Sync sources.
- 3:** The duty cycle Least Significant bits (DCB<1:0>) in the OCxCON2<10:9> register are double-buffered in PWM modes only (OCM<2:0> bits (OCxCON1<2:0>) = 111, 110). This feature is not implemented in all the devices; refer to the specific device data sheet for more information.
- 4:** These bits are not available on all devices; refer to the specific device data sheet for availability.
- 5:** When an Output Compare x module (OCx) is disabled, it sends a trigger out signal. If a second Output Compare y module (OCy) uses OCx as a Trigger or a Synchronization source, it must first deselect the OCx as its trigger source before OCx is disabled to avoid receiving an erroneous signal.

Output Compare with Dedicated Timer

Register 2-3: OCxR: Output Compare x Register

R/W-0	R/W-0	R/W-0	R/W-0	R/W-0	R/W-0	R/W-0	R/W-0
OCRB<15:8>							
bit 15				bit 8			

R/W-0	R/W-0, HS	R/W-0	R/W-0	R/W-0	R/W-0	R/W-0	R/W-0
OCRB<7:0>							
bit 7				bit 0			

Legend:

R = Readable bit	W = Writable bit	U = Unimplemented bit, read as '0'
-n = Value at POR	'1' = Bit is set	'0' = Bit is cleared x = Bit is unknown

bit 15-0 **OCRB<15:0>**: Output Compare x Primary Compare Register Value bits
 When OCM<2:0> = 0b110, the register is used for the duty cycle in an Edge-Aligned PWM mode.
 When OCM<2:0> = 0b111, 0b101 or 0b100, the register is used for generating a positive edge.
 When OCM<2:0> = 0b001, 0b010 or 0b011, the register is used for generating all edges.

Register 2-4: OCxRS: Output Compare x Secondary Register

R/W-0	R/W-0	R/W-0	R/W-0	R/W-0	R/W-0	R/W-0	R/W-0
OCR SB<15:8>							
bit 15				bit 8			

R/W-0	R/W-0, HS	R/W-0	R/W-0	R/W-0	R/W-0	R/W-0	R/W-0
OCR SB<7:0>							
bit 7				bit 0			

Legend:

R = Readable bit	W = Writable bit	U = Unimplemented bit, read as '0'
-n = Value at POR	'1' = Bit is set	'0' = Bit is cleared x = Bit is unknown

bit 15-0 **OCR SB<15:0>**: Output Compare x Secondary Register Value bits
This is the Period Register:
 If SYNCSEL<4:0> bits (OCxCON2<4:0>) = 0x1F.
 If SYNCSEL<4:0> bits (OCxCON2<4:0>) = N (where 'N' is the alternate value to select this as the Period register).
 If OCTRIG (OCxCON2<7>) = 1.
All Other Conditions:
 The period is determined outside the OCx module. Used for generating a negative edge when the OCM<2:0> bits = 0b111, 0b101 or 0b100.

dsPIC33/PIC24 Family Reference Manual

Register 2-5: OCxTMR: Output Compare x Timer Register

R-0	R-0	R-0	R-0	R-0	R-0	R-0	R-0
TMRB<15:8>							
bit 15				bit 8			

R-0	R-0	R-0	R-0	R-0	R-0	R-0	R-0
TMRB<7:0>							
bit 7				bit 0			

Legend:

R = Readable bit	W = Writable bit	U = Unimplemented bit, read as '0'	
-n = Value at POR	'1' = Bit is set	'0' = Bit is cleared	x = Bit is unknown

bit 15-0 **TMRB<15:0>**: Output Compare x Timer bits
The current value of the Output Compare x timer.

Output Compare with Dedicated Timer

3.0 MODES OF OPERATION

The Output Compare module comprises the following operating modes:

- Single Compare Match mode
- Dual Compare Match mode which generates:
 - Single Output Pulse
 - Continuous Output Pulse
- Simple Pulse-Width Modulation mode with/without Fault Protection:
 - Edge-Aligned
 - Center-Aligned
- Cascade mode (32-bit operation)

Prior to understanding the modes, it is necessary to understand the Synchronization/Trigger mechanism. In Synchronous operation, the internal timer resets to zero when the source selected by the Trigger/Synchronization Source Selection (SYNCSEL<4:0>) bits (OCxCON2<4:0>) sends a Sync signal. In Trigger mode, the internal timer is held in the Reset state until the selected Trigger source sends a Sync signal.

The Synchronous or Trigger mode is selected by the OCx Trigger/Sync Select (OCTRIG) bit (OCxCON2<7>) and the Synchronization/Trigger source can be selected by the SYNCSEL<4:0> bits (OCxCON2<4:0>), as indicated in [Section 2.0 “Output Compare Registers”](#).

Note: When the SYNCSEL<4:0> bits (OCxCON2<4:0>) = 0b00000, they put the timer in a Free-Running mode with no synchronization.
When the SYNCSEL<4:0> bits (OCxCON2<4:0>) = 0b11111, they make the timer reset when it reaches the value of OCxRS, making the OCx module use its own Sync signal.
The OCx module sends out a Synchronization/Trigger signal when its timer matches the OCxRS register.

For more information on Synchronous/Trigger mode, refer to [Section 3.3.7 “Synchronous Operation”](#).

3.1 Single Compare Match Mode

When control bits, OCM<2:0> (OCxCON1<2:0>) = 0b001, 0b010 or 0b011, the selected Output Compare channel is configured as:

- If the OCM<2:0> bits (OCxCON1<2:0>) = 0b001, the OCx pin is initially set low and a subsequent compare event with OCxR sets the pin high
- If the OCM<2:0> bits (OCxCON1<2:0>) = 0b010, the OCx pin is initially set high and a subsequent compare event with OCxR sets the pin low
- If the OCM<2:0> bits (OCxCON1<2:0>) = 0b011, the OCx pin is initially set low and a subsequent compare event with OCxR toggles the pin

In Single Compare mode, the OCxR register is used to generate the compare events. This register is loaded with a value and is compared with the Output Compare x Timer register. The interrupt is set on each compare event if there is a level change on the OCx pin.

3.1.1 SINGLE COMPARE MODE OUTPUT DRIVEN HIGH

To configure the OC module for the Single Compare mode output driven high, set control bits, OCM<2:0> (OCxCON1<2:0>) = 0b001. Once the Compare mode is enabled, the Output Compare x pin, OCx, will be initially driven low and remains low until a match between the timer and the OCxR/S registers occurs.

dsPIC33/PIC24 Family Reference Manual

Figure 3-1 shows the following key timing events:

- The OCx pin is driven high, one instruction clock after a compare match between the timer and the OCxR register. The OCx pin remains high until a mode is changed or the module is turned off.
- The timer counts up until it rolls over, or until a Synchronization event occurs, and then resets to 0x0000 on the next instruction clock.
- The respective Output Compare x Channel Interrupt Flag, OCxIF, is asserted to two instruction clocks after the OCx pin is driven high.

Figure 3-1: Single Compare Mode – Sets OCx High on Compare Match Event

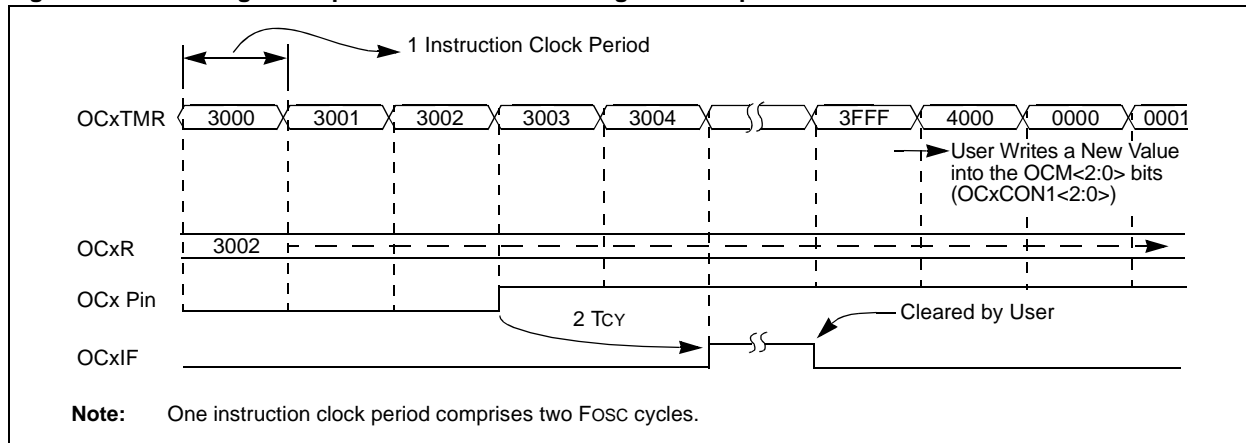

3.1.2 SINGLE COMPARE MODE OUTPUT DRIVEN LOW

To configure the OC module for the Single Compare mode output driven low, set control bits, OCM<2:0> (OCxCON1<2:0>) = 0b010. Once the Compare mode is enabled, the output pin, OCx, will be initially driven high and remains high until a match occurs between the timer and the OCxR/S registers. Figure 3-2 shows the following key timing events:

- The OCx pin is driven low, one instruction clock after a compare match event occurs between the timer and the OCxR register. The OCx pin remains low until a mode is changed or the module is turned off.
- The timer counts up until it rolls over, or until a Synchronization event occurs, and then resets to 0x0000 on the next instruction clock.
- The respective Output Compare x Channel Interrupt Flag, OCxIF, is asserted to two instruction clocks after the OCx pin is driven low.

Figure 3-2: Single Compare Mode – Forces OCx Low on Compare Match Event

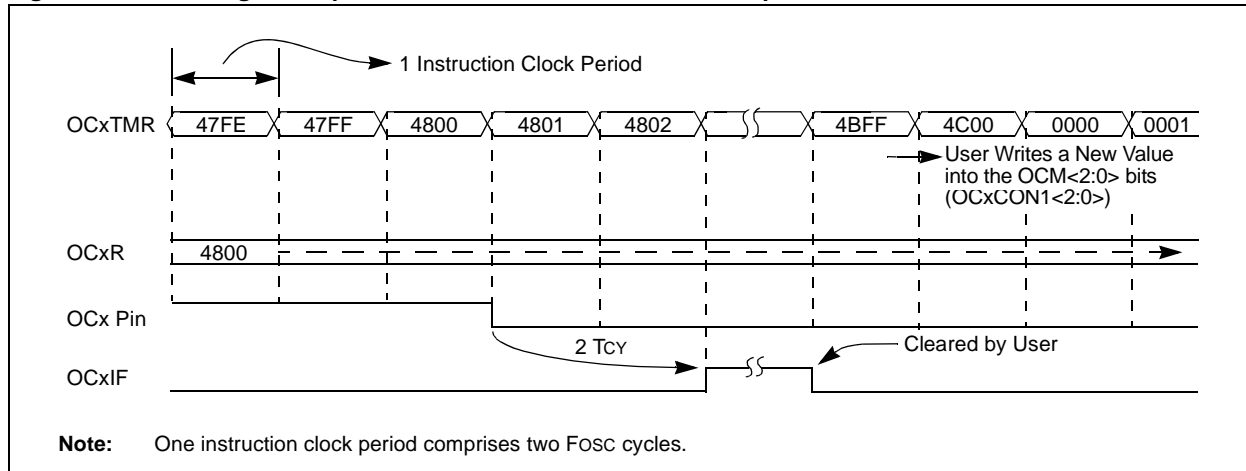

Output Compare with Dedicated Timer

3.1.3 SINGLE COMPARE MODE TOGGLE OUTPUT

To configure the OC module for the Single Compare mode toggle output, set control bits, $OCM\langle 2:0 \rangle$ ($OCxCON1\langle 2:0 \rangle$) = 0b011. Once the Single Compare mode is enabled, the output pin, OCx, toggles on every match event between the timer and the OCxR/S registers. [Example 3-1](#) shows the sample code for the Single Compare mode toggle output.

[Figure 3-3](#) shows the following key timing events.

- The OCx pin is toggled, one instruction clock after a compare match occurs between the Timer and the OCxR register. The OCx pin remains at this new state until the next toggle event, or until a mode is changed or the module is turned off.
- The timer counts up until it rolls over, or until a Synchronization occurs, and then resets to 0x0000 on the next instruction clock.
- The respective Output Compare x Channel Interrupt Flag, OCxIF, is asserted to two instruction clocks after the OCx pin is toggled.
- The internal OCx pin output logic is set to a logic '0' on a device Reset. However, the operational OCx pin state in the Toggle mode can be set by the user software.

Figure 3-3: Single Compare Mode – Toggle Output on Compare Match Event ($OCxTMR > OCxR$)

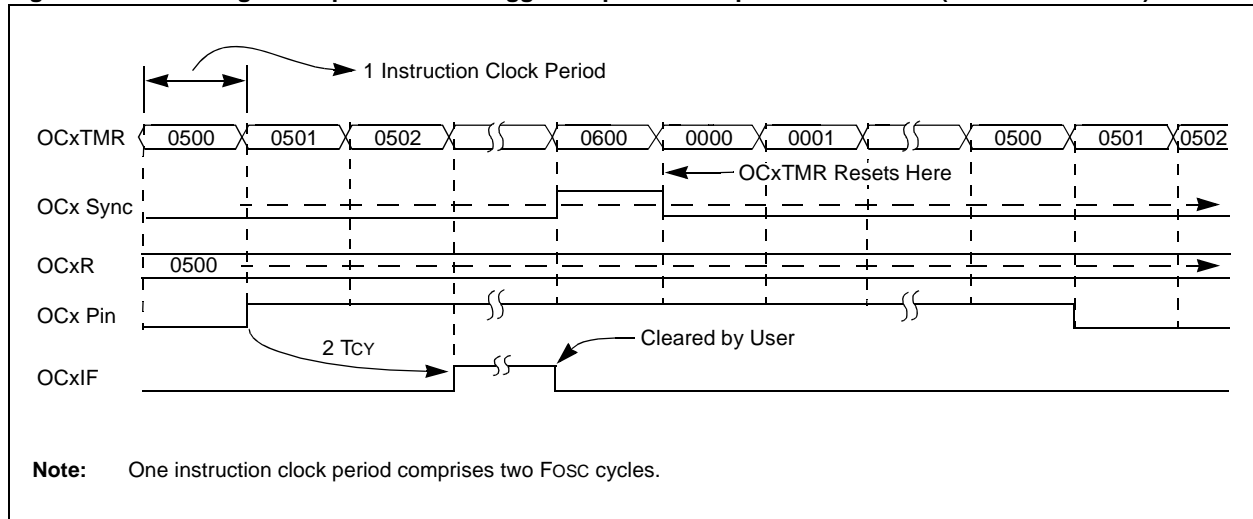

Example 3-1: Single Compare Mode Toggle Output

```
OC1CON1 = 0;          /* It is a good practice to clear off the control bits initially */
OC1CON2 = 0;
OC1CON1bits.OCTSEL = 0x07; /* This selects the peripheral clock as the clock input to the OC
                             module */
OC1R = 1000;         /* This is just a typical number, user must calculate based on the
                     waveform requirements and the system clock */
OC1CON1bits.OCM = 3; /* This selects and starts the toggle mode */
```

dsPIC33/PIC24 Family Reference Manual

3.1.4 SPECIAL CASES OF SINGLE COMPARE MODE

Table 3-1 lists the special cases of Single Compare mode.

Table 3-1: Special Cases of Single Compare Mode

Special Conditions	Operation	Output
When the OCxR register is greater than the timer period as determined by the Sync source	No compare event occurs and the compare output remains at the initial condition.	No change in output level
When the OCxR register is equal to the timer period as determined by the Sync source	The compare output functions normally. Combining this with the Toggle mode can be used to generate a fixed frequency square wave, as illustrated in Figure 3-4.	Output level transition
When the module is enabled into Single Compare mode (OCxR = 0x0000) and the timer is held in Reset, the Sync source is active	The compare output remains in the initial condition.	No change in output level
If, after a compare event, the OCxR register is cleared and the Sync source becomes active	Output remains in the new state.	No further change in output level

Figure 3-4: Single Compare Mode – Toggle Output on Compare Match Event (OCxTMR = OCxR)

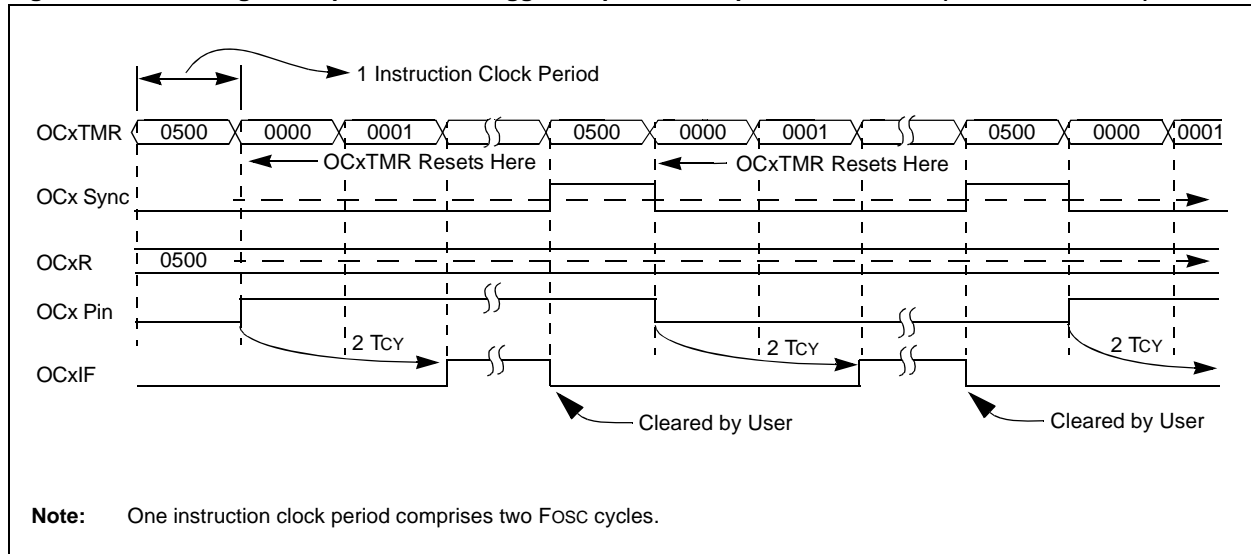

Output Compare with Dedicated Timer

3.2 Dual Compare Match Mode

When control bits, $OCM<2:0>$ ($OCxCON1<2:0>$) = 0b100 or 0b101, the selected Output Compare channel is configured for one of the two following Dual Compare Match modes:

- Dual Compare Single Output Pulse mode
- Dual Compare Continuous Output Pulse mode

In the Dual Compare Match mode, the module uses both the $OCxR$ and $OCxRS$ registers for the compare match events. The $OCxR$ register is compared with the incrementing timer count, $OCxTMR$ and the rising (leading) edge of the pulse is generated at the OCx pin on a compare match event. The $OCxRS$ register is then compared to the same incrementing timer count, $OCxTMR$, and the falling (trailing) edge of the pulse is generated at the OCx pin on a compare match event.

3.2.1 DUAL COMPARE SINGLE OUTPUT PULSE MODE

When control bits, $OCM<2:0>$ ($OCxCON1<2:0>$) = 0b100, the selected Output Compare channel is configured so that the OCx pin is initialized low and a single output pulse is generated (see [Figure 3-5](#) and [Figure 3-6](#)). Once the Dual Compare Single Output Pulse mode is enabled, the OCx pin will be driven low. The OCx pin will be driven high after a first timer compare match with the Output Compare x register, $OCxR$.

When the incrementing timer count matches the Output Compare x Secondary register, $OCxRS$, the second and trailing edge (high-to-low) of the pulse is driven onto the OCx pin. At this second compare, the $OCxIF$ interrupt flag bit gets set. [Example 3-2](#) shows the code for the Dual Compare Single Output Pulse mode. [Table 3-2](#) shows the calculated examples for the Dual Compare Single Output Pulse mode. [Equation 3-1](#) shows the formula for the calculations for the Dual Compare Single Output Pulse mode.

Note: If another write on the mode bits with the same value occurs on the same control bits, a new single output pulse sequence is generated, even if there is no change after the falling edge of the pulse.

The value of the $OCxRS$ register must be greater than the $OCxR$ register by a minimum of 2.

Figure 3-5: Dual Compare Mode Single Output Pulse

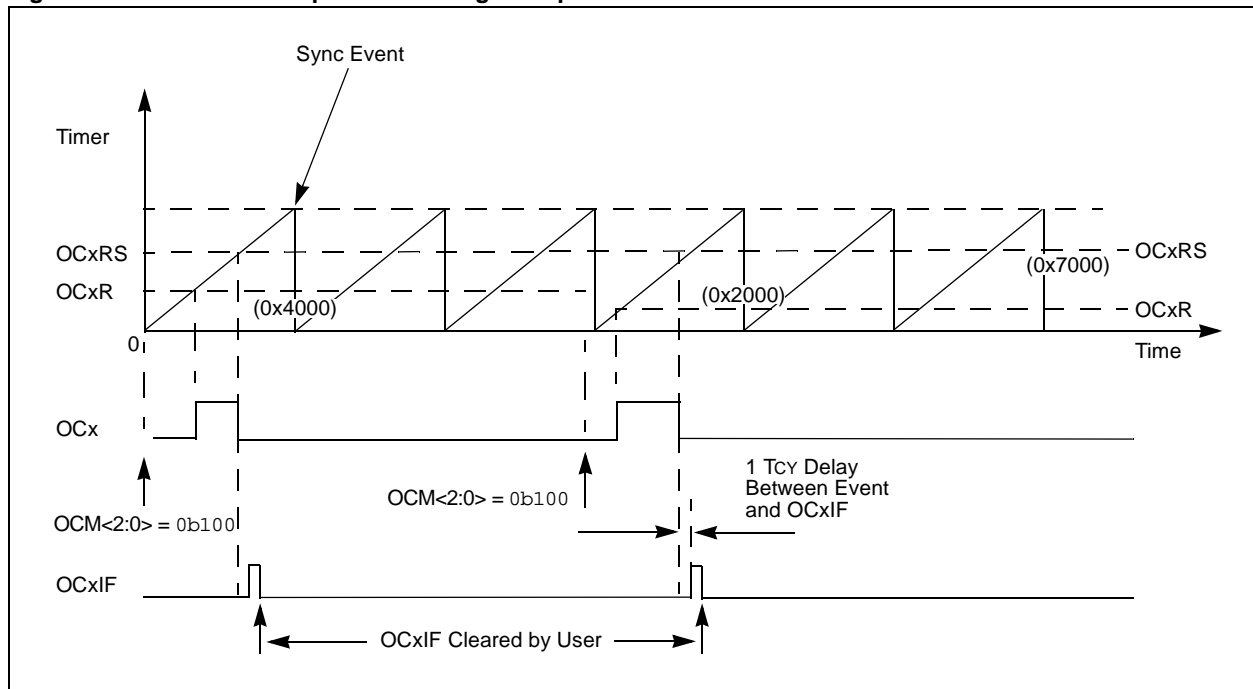

dsPIC33/PIC24 Family Reference Manual

Figure 3-6: Dual Compare Mode

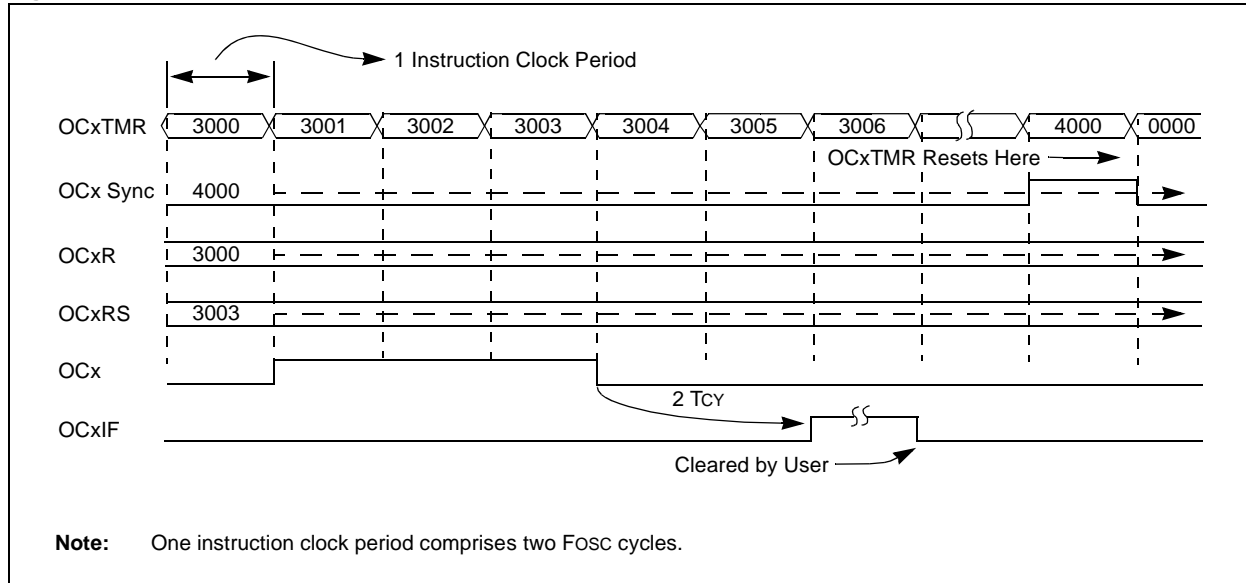

3.2.1.1 To Set Up Single Output Pulse Generation

To configure the module for the generation of a single output pulse, perform the following steps:

1. Determine the instruction cycle time, T_{CY} .
2. Calculate the desired pulse-width value based upon T_{CY} .
3. Calculate the time to start the pulse from the timer start value of 0x0000.
4. Write pulse-width start and stop times into the OCxR and OCxRS registers.
5. Select the SYNCSEL<4:0> bits (OCxCON2<4:0>) so that the synchronization is active after the timer is equal to, or greater than, the value in OCxRS.
6. Set the OCM<2:0> bits (OCxCON1<2:0>) = 0b100; the pulse will be generated.
7. Issue another write to set the OCM<2:0> bits (OCxCON1<2:0>) = 0b100 to initiate another single pulse with the same parameters.
8. Disable the OCx by writing the OCM<2:0> bits (OCxCON1<2:0>) = 0b000 to change the parameters and then enable the OCx by writing the OCM<2:0> bits (OCxCON1<2:0>) = 0b100 to initiate another single pulse with different parameters.

Output Compare with Dedicated Timer

Table 3-2 provides examples of single output pulse-width calculations.

Table 3-3 provides examples of the Dual Compare Match mode generating a single output pulse.

Table 3-2: Dual Compare Mode – Single Output Pulse-Width Calculation Examples

Instruction Cycle Time (Tcy) ⁽¹⁾	Desired On Time		Start Pulse Time from Timer = 0x0000		End Pulse Time (OCxRS) Register
	Time	Hex Value	Time	Hex Value (OCxR)	
16.6 ns	1 μs	0x003C	10 μs	0x0258	0x0294
30 ns	1 μs	0x0021	10 μs	0x014D	0x016E
30 ns	2 μs	0x0042	10 μs	0x014D	0x018F
50 ns	3 μs	0x003C	10 μs	0x00C8	0x0104
62.5 ns	3 μs	0x0030	10 μs	0x00A0	0x0D0
100 ns	5 μs	0x0032	50 μs	0x0064	0x0096
300 ns	10 μs	0x0021	100 μs	0x014D	0x018F
500 ns	20 μs	0x0028	500 μs	0x03E8	0x0410
500 ns	30 μs	0x003C	2 ms	0x0FA0	0x0FDC

Note 1: Verify the specific device data sheet for the minimum Tcy of operation.

Equation 3-1: Dual Compare Mode – Single Output Pulse Width

Value = Desired Time/Instruction Cycle Time (TCY)

Example 3-2: Dual Compare Mode – Single Output Pulse Width

```

OC1CON1 = 0;          /* It is a good practice to clear off the control bits initially */
OC1CON2 = 0;
OC1CON1bits.OCTSEL = 0x07; /* This selects the peripheral clock as the clock input to the OC
                             module */
OC1R = 1000;         /* This is just a typical number, user must calculate based on the
                             waveform requirements and the system clock */
OC1RS = 2000;
OC1CON1bits.OCM = 4; /* This selects and starts the Single Output Pulse mode */
    
```

dsPIC33/PIC24 Family Reference Manual

Table 3-3: Special Cases for Dual Compare Match Mode Generating a Single Output Pulse

Special Conditions	Operation	Output
Synchronization occurs when the timer value is equal to OCxRS	Timer resets to zero in the next cycle, but the pulse is unaffected.	Pulse
Synchronization occurs before the timer value reaches OCxR	Timer resets to zero before any output transition.	Remains low
Synchronization occurs before the timer value reaches OCxRS, but after it reaches OCxR	Only a single transition (low-to-high) is generated (see Figure 3-7).	Low/High
OCxR = OCxRS = 0x0000 and Sync occurs	The output is initialized low and does not change. No interrupt is generated.	Remains low
OCxRS < OCxR	The timer counts up to the first Output Compare x register (TMRx = OCxR) and the first rising edge is generated. The timer then continues to count and eventually resets when the synchronization occurs or rolls over. The timer then restarts from 0x0000 and counts up to the Output Compare x Secondary register (TMRx = OCxRS) and the second falling edge of the signal is generated. The falling edge of the output pulse generates an interrupt condition.	Pulse
OCxR = OCxRS	The timer counts up to the first Output Compare x register (Timer = OCxR) and the first rising edge is generated. The timer continues to count and eventually resets when the synchronization occurs or a rollover from 0xFFFF occurs. The timer then restarts from 0x0000 and counts up to the Output Compare x Secondary register (TMRx = OCxRS), and the second falling edge of the signal is generated. The falling edge of the output pulse generates an interrupt condition.	Pulse
OCxR = 0x0000 and OCxRS > OCxR	The first cycle of the timer counts until the synchronization occurs or rolls over and the Output Compare x pin remains low. After the Timer register resets to zero, the Output Compare x pin goes high. In the next timer match with the register, OCxRS, the Output Compare x pin goes low and remains. The falling edge of the output pulse generates an interrupt condition (see Figure 3-8).	Pulse except for the first cycle

Output Compare with Dedicated Timer

Figure 3-7: Dual Compare Mode – Single Output Pulse (Sync Before Timer Reaches OCxRS)

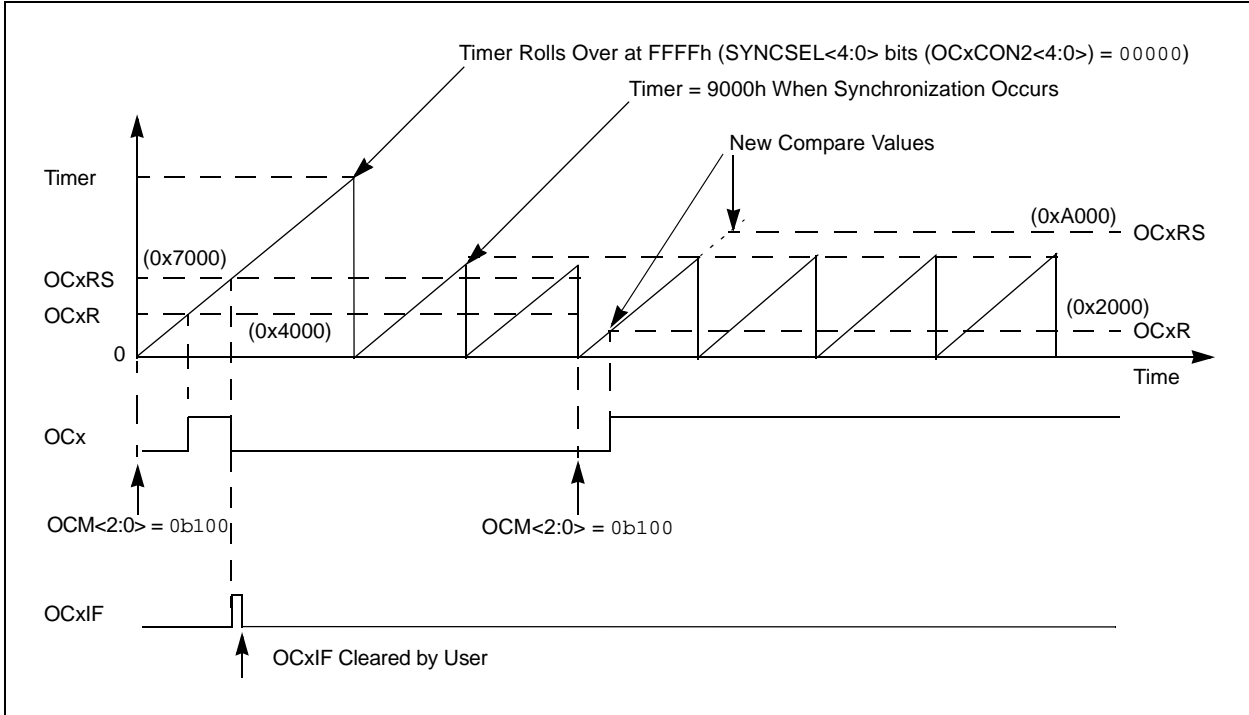
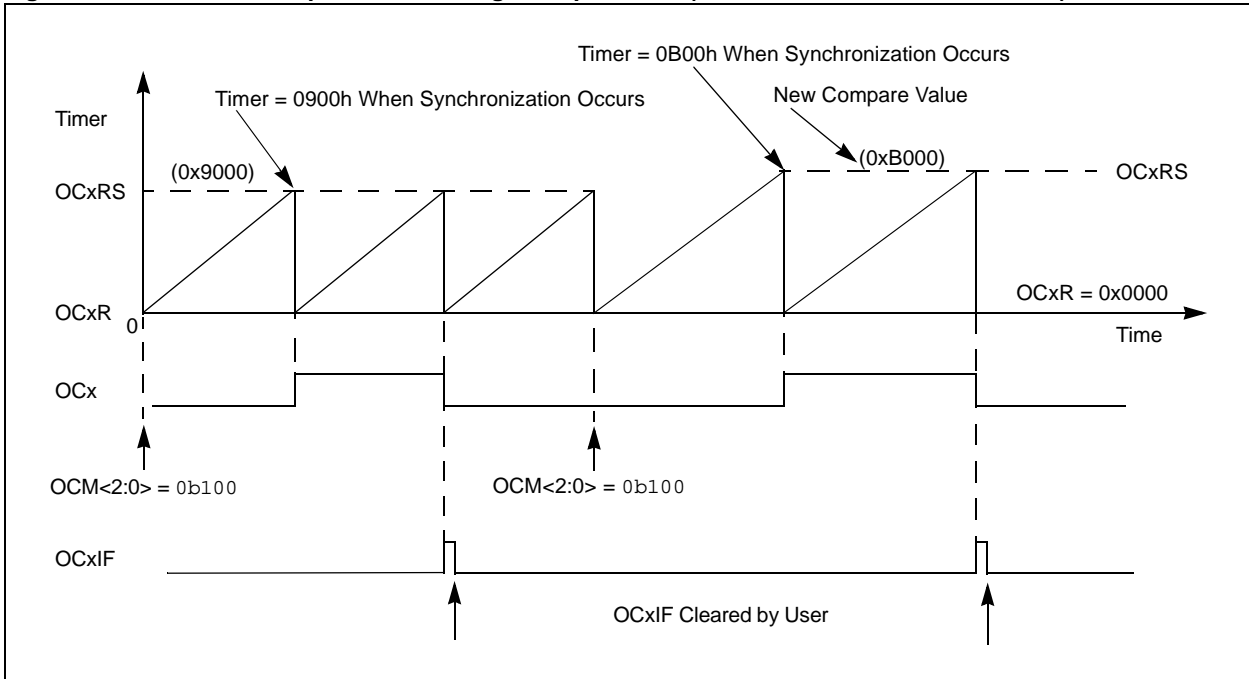

Figure 3-8: Dual Compare Mode – Single Output Pulse (OCxR = 0x0000, OCxRS > OCxR)



dsPIC33/PIC24 Family Reference Manual

3.2.2 DUAL COMPARE CONTINUOUS OUTPUT PULSE MODE

When the OCx Mode Select bits, OCM<2:0> (OCxCON1<2:0>) = 0b101, the selected Output Compare channel is configured so that the OCx pin is initialized low and continuous output pulses are generated. Figure 3-9 shows the Dual Compare Continuous Output Pulse mode. Once the Dual Compare Continuous Output Pulse mode is enabled, the pin state will be driven low. The OCx pin will be driven high after a first timer compare match with the Output Compare x register, OCxR.

When the incrementing timer count matches the Output Compare Secondary register, OCxRS, the second and trailing edges (high-to-low) of the pulse are driven onto the OCx pin. At this second compare, the OCxIF interrupt flag bit is set. Example 3-3 shows the sample code for the Dual Compare Continuous Output Pulse mode generation. Table 3-4 shows the calculated examples for the Dual Compare Continuous Output Pulse mode.

Note: Unlike the Dual Compare Single Output Pulse mode, the output pulses continue indefinitely until the mode is terminated by the user firmware or by a Reset. The falling edge of each output pulse sets the interrupt flag.

One way of generating a pulse with 50% duty cycle is by setting $OCxR = OCxRS$ and self-synchronizing.

Figure 3-9: Dual Compare Mode – Continuous Output Pulses

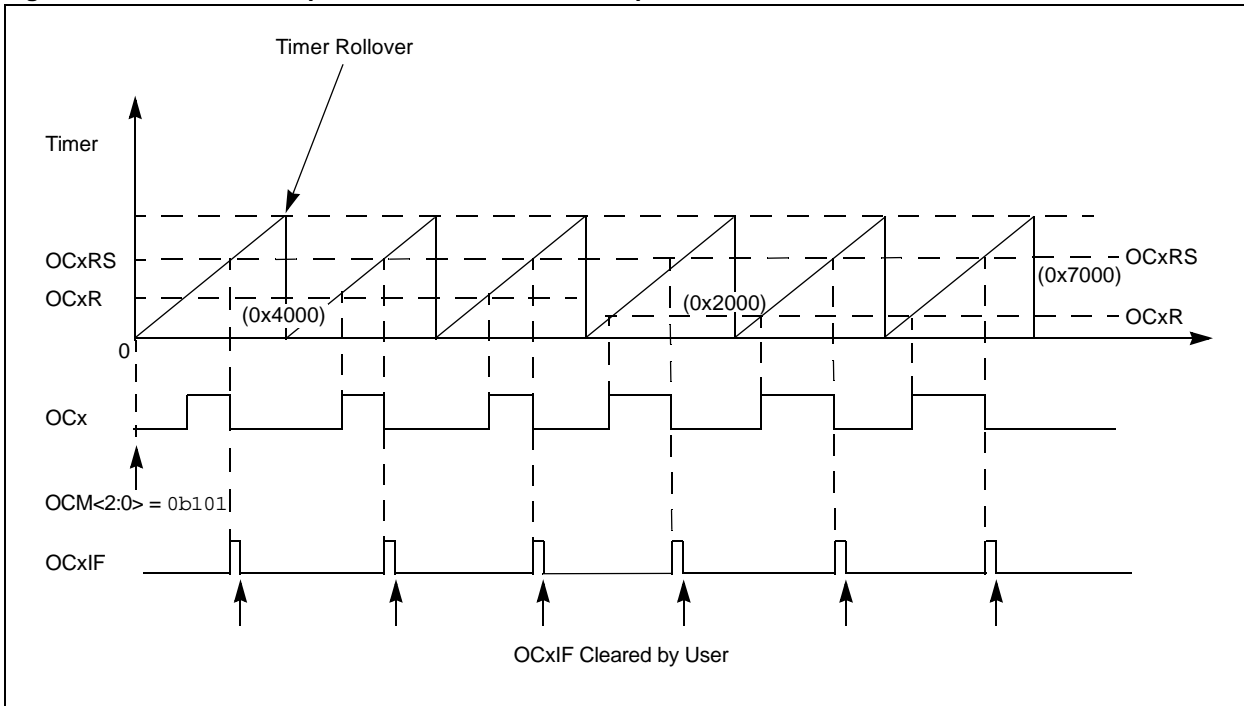

Output Compare with Dedicated Timer

3.2.3 SETUP FOR CONTINUOUS OUTPUT PULSE GENERATION

To configure the OCx module for the generation of a continuous stream of output pulses, perform the following steps:

1. Determine the instruction cycle time, Tcy.
2. Calculate the timer to start the pulse width from the timer start value of 0x0000.
3. Calculate the timer to stop the pulse width from the timer start value of 0x0000.
4. Write the pulse-width start and stop values into the OCxR and OCxRS registers, respectively. The Sync signal should occur when OCxRS = timer or after.
5. Set the OCM<2:0> bits (OCxCON1<2:0>) = 0b101; the timer must be enabled.

Example 3-3: Continuous Output Pulse Generation

```

OC1CON1 = 0;
OC1CON2 = 0; /* It is a good practice to clear off the control bits initially */
OC1CON1bits.OCTSEL = 0x07; /* This selects the peripheral clock as the clock input to the OC
module */
OC1R = 1000; /* This is just a typical number, user must calculate based on the
waveform requirements and the system clock */
OC1RS = 2000;
T1CON = 0;
PR1 = 3000; /* Determines the period */
OC1CON2bits.SYNCSEL = 0x0B; /* TMR1 is the sync source */
OC1CON1bits.OCM = 5; /* This selects the Continuous Pulse mode*/
T1CONbits.TON = 1; /* OC1TMR does not run until the sync source is switched on */
    
```

Table 3-4: Dual Compare Mode – Continuous Output Pulse-Width Calculation Examples

Instruction Cycle Time (Tcy) ⁽¹⁾	Desired Pulse Width		Start Pulse Time from Timer = 0x0000		End Pulse Time from Timer = 0x0000		Pulse Period
	Time	Value	Time	Value (OCxR)	Time	Value (OCxR)	
30 ns	1 μs	0x0021	10 μs	0x014D	0x016F	0x015D	—
30 ns	2 μs	0x0042	10 μs	0x014D	0x0190	0x016F	—
50 ns	3 μs	0x003C	10 μs	0x00C8	0x0105	0x00E6	—
62.5 ns	3 μs	0x0030	10 μs	0x00A0	13 μs	0x0D0	Select appropriate Sync source to set the period. If the OCx module is self-synchronized, the period is equal to the end pulse time.
100 ns	5 μs	0x0032	10 μs	0x0064	15 μs	0x0096	
300 ns	10 μs	0x0021	100 μs	0x014D	110 μs	0x018F	
500 ns	20 μs	0x0028	500 μs	0x03E8	520 μs	0x0410	
500 ns	30 μs	0x003C	2 ms	0x0FA0	2.03 ms	0x0FDC	

Note 1: Verify the device data sheet for the minimum Tcy of operation.

Equation 3-2:

$$\text{Value} = \text{Desired Time} / \text{Instruction Cycle Time (TCY)}$$

Note: The timer module with the same clock as OCx is used as the Sync source in [Table 3-4](#).

dsPIC33/PIC24 Family Reference Manual

Table 3-5: Special Cases for Dual Compare Match Mode Generating Continuous Output Pulse

Special Condition	Operation	Output
Synchronization occurs when the timer value is equal to OCxRS	Timer resets to zero in the next cycle, but the pulse is unaffected (see Figure 3-10).	Pulses
Synchronization occurs before the timer value reaches OCxR	Timer resets to zero before any output transition.	Remains low
Synchronization occurs before the timer value reaches OCxRS, but after it reaches OCxR	Only a single transition, low-to-high, is generated (see Figure 3-11).	Low/High
OCxR = OCxRS = 0x0000 and synchronization occurs	The output is initialized low and does not change. No interrupt is generated.	Remains low
OCxRS < OCxR	The timer counts up to the first compare (TMRx = OCxR) and the first rising edge is generated. The timer then continues to count and eventually resets when synchronization occurs or rolls over. The timer then restarts from 0x0000 and counts up to the second compare (TMRx = OCxRS) and the second falling edge of the signal is generated. The falling edge of the output pulse generates an interrupt condition. The sequence repeats until the module is disabled.	Pulses
OCxR = OCxRS	The timer counts up to the first compare (Timer = OCxR) and the first rising edge is generated. The timer continues to count and eventually resets when synchronization occurs or a roll-over from FFFFh occurs. The timer then restarts from 0x0000 and counts up to the second compare (TMRx = OCxRS), and the second falling edge of the signal is generated. The falling edge of the output pulse generates an interrupt condition. The sequence repeats until the module is disabled.	Pulses
OCxR = 0x0000 and OCxRS > OCxR	The first cycle of the timer counts until synchronization occurs or rolls over; the Output Compare x pin remains low. After the Timer register resets to zero, the Output Compare x pin goes high. In the next timer match with the Output Compare x Secondary register, OCxRS, the Output Compare x pin goes low and remains low. The falling edge of the output pulse generates an interrupt condition (see Figure 3-12). The sequence repeats until the module is disabled.	Pulses except for the first cycle

Output Compare with Dedicated Timer

Figure 3-10: Dual Compare Mode – Continuous Output Pulse (Sync Occurs When Timer = OCxRS)

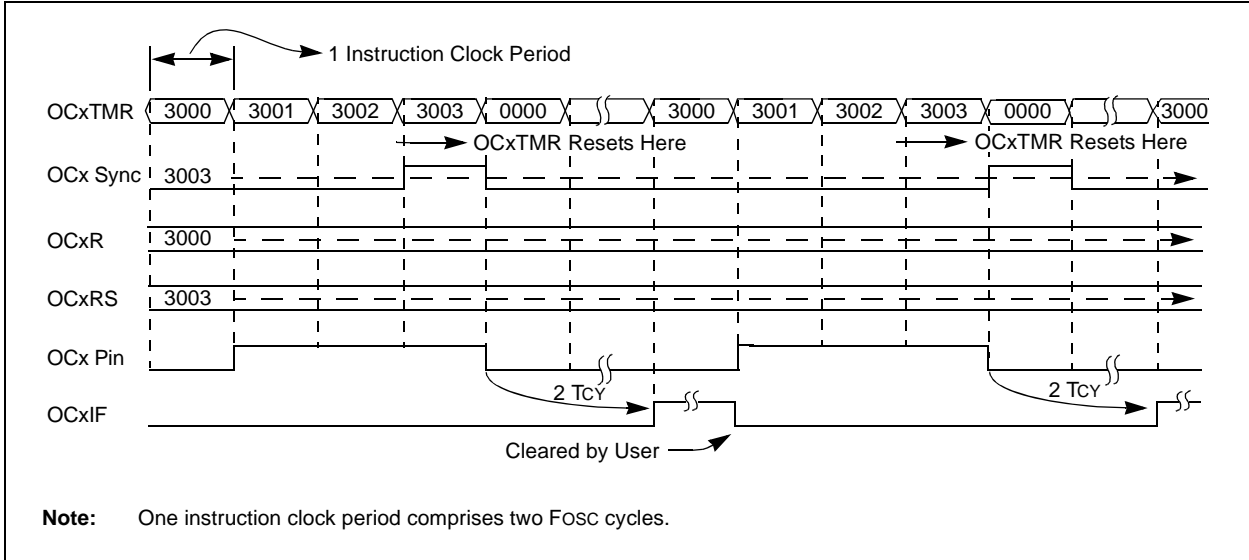
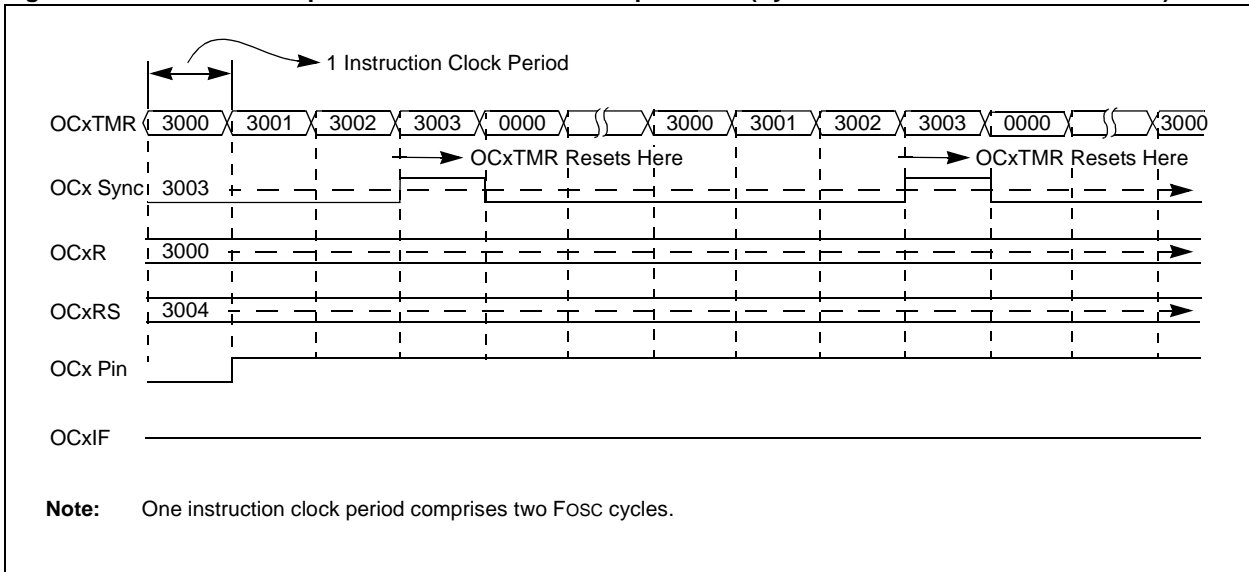
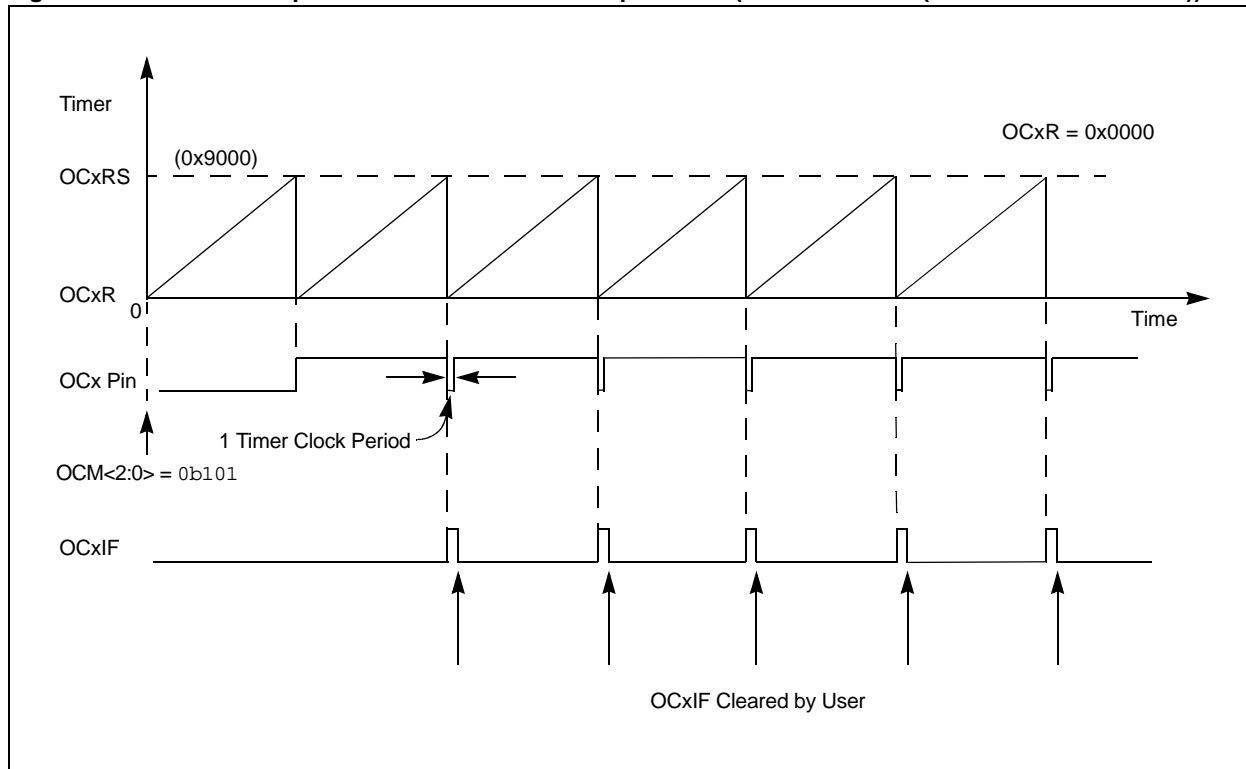

Figure 3-11: Dual Compare Mode – Continuous Output Pulse (Sync Before Timer Reaches OCxRS)



dsPIC33/PIC24 Family Reference Manual

Figure 3-12: Dual Compare Mode – Continuous Output Pulse (OCxR = 0x0000 (SYNCSEL<4:0> = 0x1F))



Output Compare with Dedicated Timer

3.3 Pulse-Width Modulation Mode

When control bits, $OCM<2:0>$ ($OCxCON1<2:0>$) = $0b110$ or $0b111$, the Pulse-Width Modulation (PWM) mode is selected. The registers, $OCxR$ and $OCxRS$, are double-buffered in these modes, that is, the changes on these registers will be reflected only after a timer rollover from $0xFFFF$ or after a Sync event occurs. As a result, any changes in the $OCxR$ and $OCxRS$ registers during operation occurs only with the next pulse. Furthermore, in PWM mode, the Fault input is supported as described in the following sections.

3.3.1 EDGE-ALIGNED PWM MODE

When control bits, $OCM<2:0>$ ($OCxCON1<2:0>$) = $0b110$, the Edge-Aligned PWM mode of operation is selected. The $OCxR$ register contains the current duty cycle and the $SYNCSELx$ bits determine the period. The $OCxRS$ register can be made to determine the period by setting the $SYNCSEL<4:0>$ bits ($OCxCON2<4:0>$) = $0x1F$.

Note: This is a migration issue for applications. In the OC module without dedicated timers (see “Output Compare” chapter in the specific device data sheet); the $OCxRS$ register served as a double-buffer to $OCxR$. In this version, both the registers are double-buffered.

Figure 3-13 and Figure 3-14 show the PWM mode of operation.

Edge-Aligned PWM Mode Operation:

- When synchronization occurs, the following four events occur on the next increment cycle:
 - The timer is reset to zero and resumes counting
 - The OCx pin is set high (if $OCxRS = 0b0000$, the OCx pin may not be set)
 - The $OCxR$ and $OCxRS$ Buffered registers are updated from $OCxR$ and $OCxRS$
 - The interrupt flag, $OCxIF$, is set
- When the timer and $OCxR$ match, the pin may be set low. This match does not generate the interrupts.

Figure 3-13: PWM Output Timing

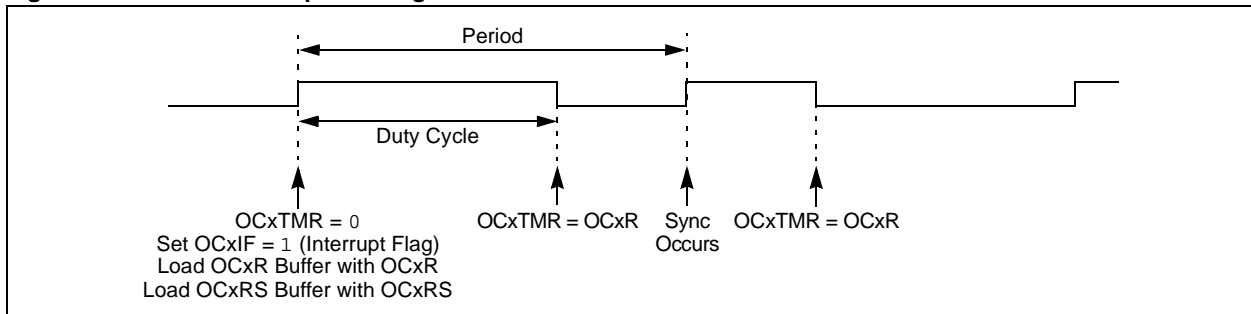
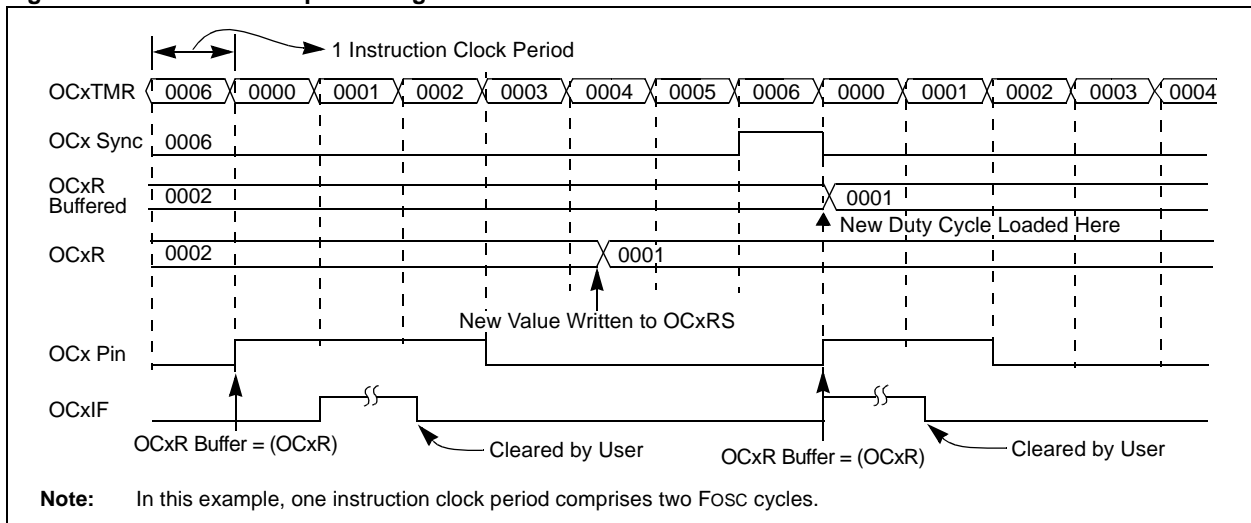

Figure 3-14: PWM Output Timing



dsPIC33/PIC24 Family Reference Manual

3.3.2 EDGE-ALIGNED PWM MODE INITIALIZATION

Once the PWM mode is enabled by setting the OCM<2:0> bits (OCxCON1<2:0>) = 0b110, the OCx pin would be driven low if OCxR = 0x0000. If OCxR is not equal to zero, then the OCx pin will be set high (see [Figure 3-15](#) and [Figure 3-16](#)).

When OCxR is not equal to zero and the pin state is set to high, then the first match between the OCxR and the timer clears the OCx pin. The OCx pin will remain low until a valid compare between synchronization occurs or until a rollover occurs (see [Figure 3-17](#)).

Figure 3-15: Edge-Aligned PWM Mode with OCxR = 0 – At Module Initialization, OCxR = 0x0000, OCxRS = 0x5000

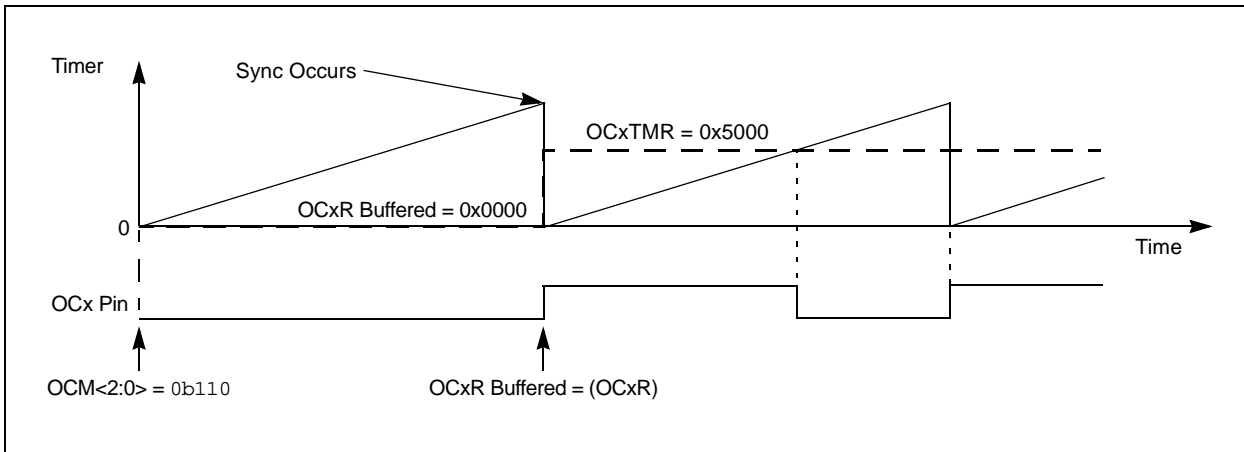
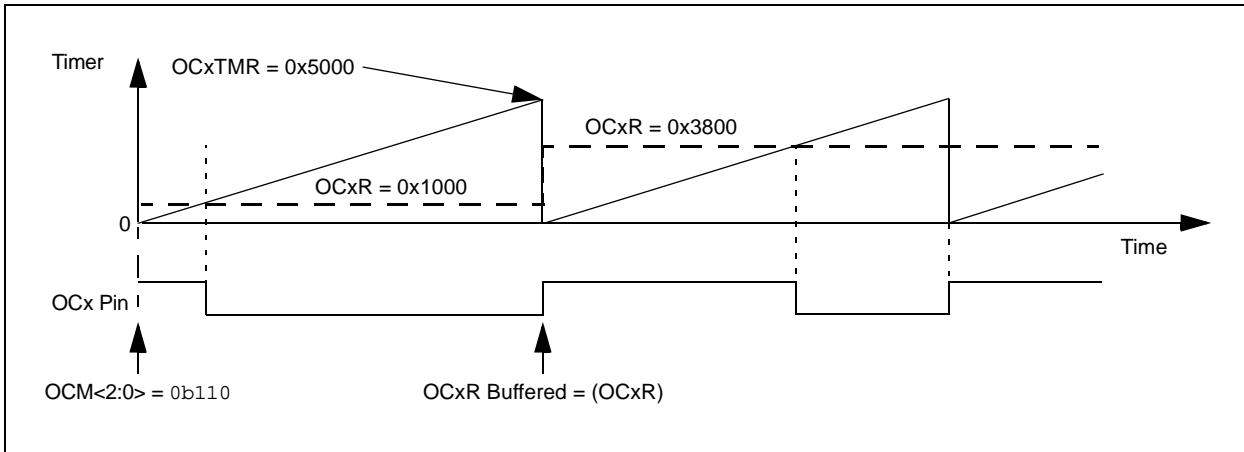

Figure 3-16: Edge-Aligned PWM Mode with OCR > 0 – At Module Initialization, OCxR = 0x1000, OCxRS = 0x5000



Output Compare with Dedicated Timer

3.3.3 USER SETUP FOR PWM OPERATION

To configure the OCx module for PWM operation, perform the following steps (Example 3-4 shows the example code for the PWM):

1. Determine the instruction cycle time, T_{CY}.
2. Calculate the desired pulse on time value based upon T_{CY} and write it into OCxR.
3. Calculate the period value based upon T_{CY} and write it into OCxRS.
4. Write 0x1F to the SYNCSEL<4:0> bits (OCxCON2<4:0>) to select self-synchronization.
5. Set the required clock source.
6. Set the OCM<2:0> bits (OCxCON1<2:0>) = 0b110 to select and start Edge-Aligned PWM mode.

Example 3-4: PWM Mode

```

OC1CON1 = 0;          /* It is a good practice to clear off the control bits initially */
OC1CON2 = 0;
OC1CON1bits.OCTSEL = 0x07; /* This selects the peripheral clock as the clock input to the OC
                             module */
OC1R = 1000;          /* This is just a typical number, user must calculate based on the
                             waveform requirements and the system clock */
OC1RS = 2000;         /* Determines the Period */
OC1CON2bits.SYNCSEL = 0x1F; /* This selects the synchronization source as itself */
OC1CON1bits.OCM = 6;   /* This selects and starts the Edge Aligned PWM mode*/
    
```

3.3.4 PWM SPECIAL COMPARE MODE CONDITIONS

Table 3-6 lists the PWM Special Compare mode conditions.

Table 3-6: PWM Special Compare Mode Conditions

Special Condition	Operation	Output
OCxR = 0	The OCx pin would be set low (see Figure 3-17).	Low
OCxR > OCxRS	The OCx pin would be set high (see Figure 3-18).	High
OCxR = OCxTMR and synchronization occurs	The OCx pin would remain high (see Figure 3-19).	High

Figure 3-17: PWM Output Timing (0% Duty Cycle, OCxR = 0x0000)

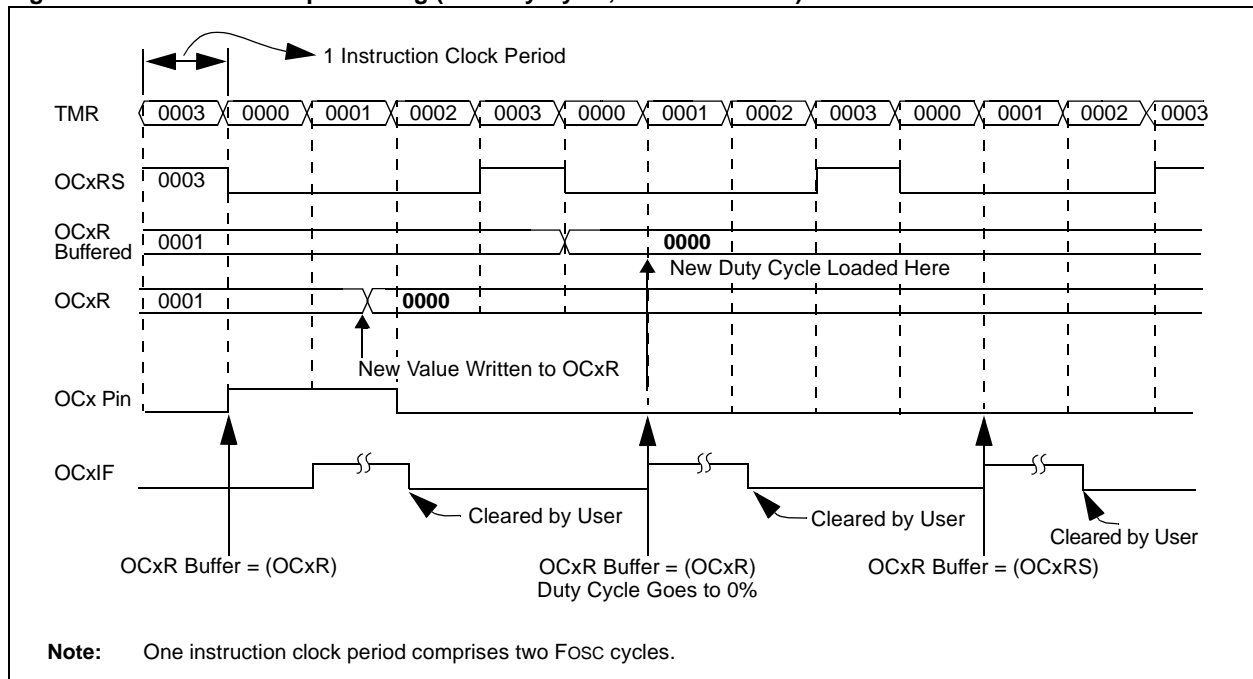

dsPIC33/PIC24 Family Reference Manual

Figure 3-18: PWM Output Timing (100% Duty Cycle, OCxR > OCxRS (SYNCSEL<4:0> = 0x1F))

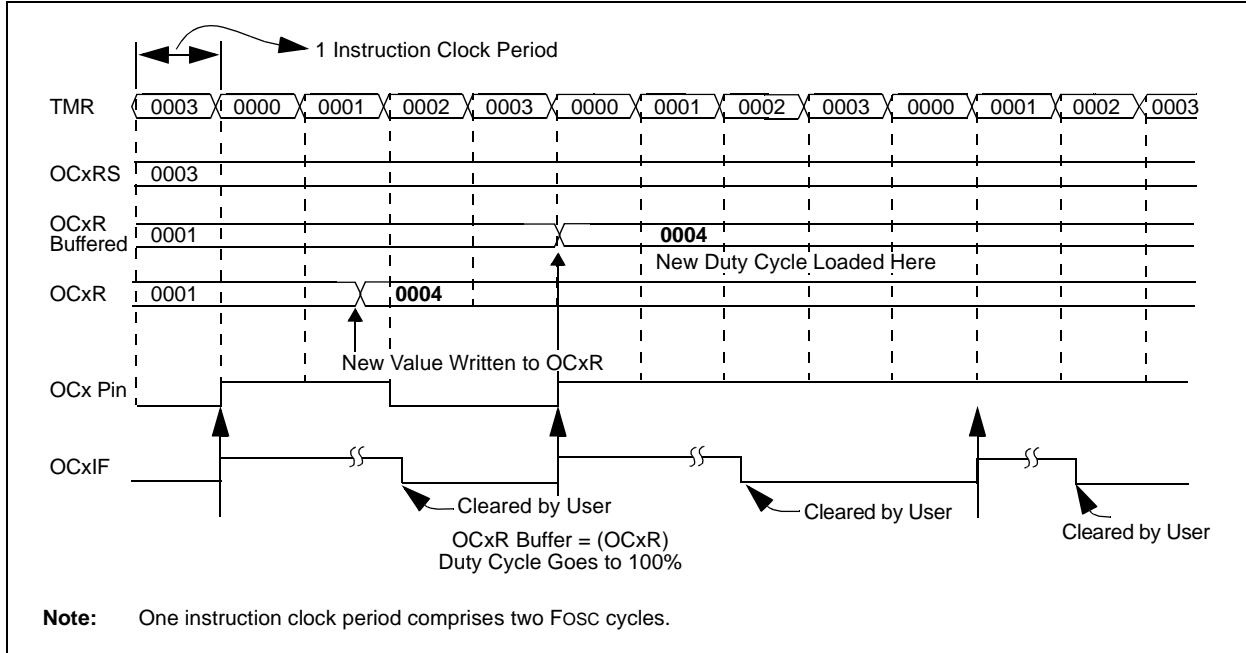
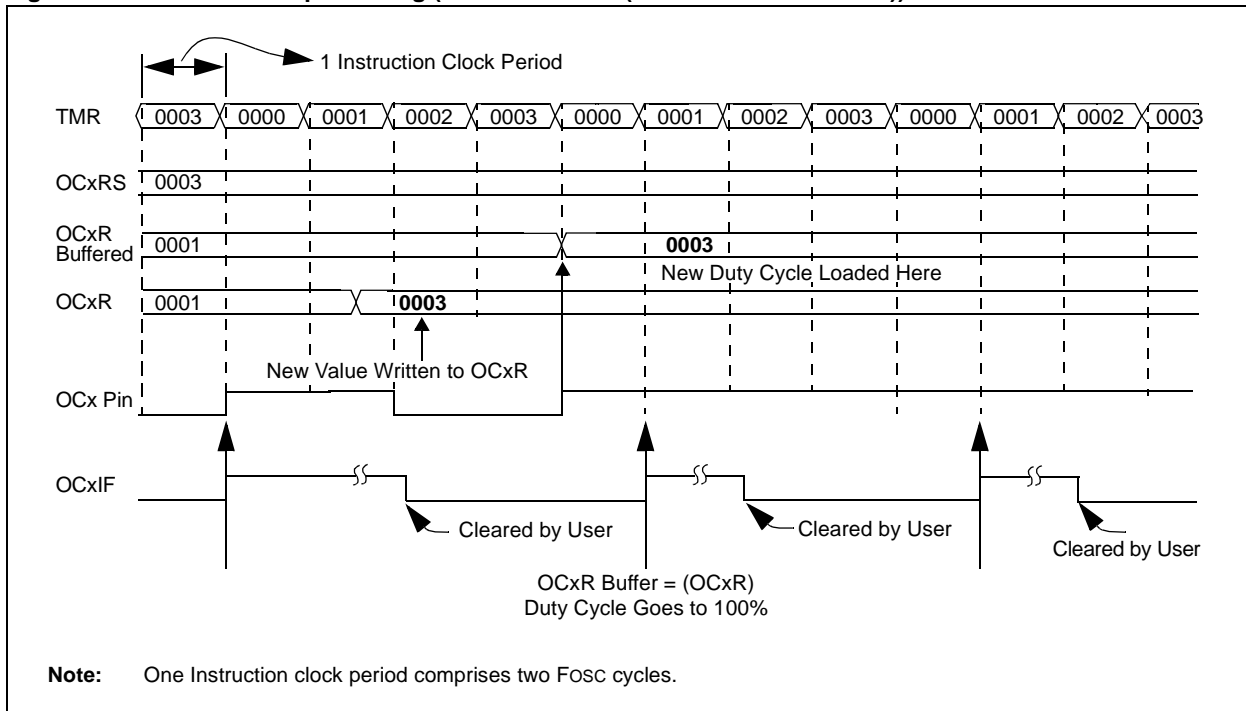

Figure 3-19: PWM Output Timing (OCxR = OCxRS (SYNCSEL<4:0> = 0x1F))



Output Compare with Dedicated Timer

3.3.5 CENTER-ALIGNED PWM MODE

In this mode, the OCM<2:0> bits (OCxCON1<2:0>) = 0b111 functions are the same as Continuous Pulse mode, OCM<2:0> bits (OCxCON1<2:0>) = 0b101, and the only differences are:

- The OCxR and OCxRS registers are double-buffered, which means that the new register value would be effective only after a timer rollover or synchronization.
- Fault control and pins are used.

Note: Center-alignment does not mean the pulse is exactly aligned to the center of the pulse width. It indicates that the on time of the pulse can be positioned anywhere within the period.

3.3.6 FAULT INPUT AND CONTROL

When operating in either a Center-Aligned PWM mode or in an Edge-Aligned PWM mode (OCM<2:0> bits (OCxCON1<2:0>) = 0b111 or 0b110), the Fault pin and its controls can be activated. The Fault pin, OCFA, is always available and controls all of the OCx modules. However, another Fault pin, OCFB, may also be available. The Fault pin is controlled by the register bits, ENFLT_x (OCxCON1<9:7>). If these bits are set to zero, the corresponding Fault input pins (OCFA, OCFB, etc., refer to the specific device data sheet for Fault signal mappings) are ignored. The status of the Fault input can be observed in the corresponding OCFLT_x (OCxCON1<6:4>) register bits.

Note: The Output Compare x Fault pins, OCFA and OCFB, are active-low signals.

When a Fault occurs (OCF_x = 0), the OC_x pin output level is determined by the FLTOUT bit (OCxCON2<14>). The tri-stating of the OC_x pin during a Fault condition is controlled by the FLTRIEN bit (OCxCON2<13>).

Note: For more information on how Fault pins are assigned to the various OC_x peripherals, refer to the specific device data sheet.

The Fault control can operate in the following two modes based on the FLTMD bit (OCxCON2<15>):

- Inactive mode
- Cycle-by-Cycle mode

3.3.6.1 Inactive Mode

When the FLTMD bit (OCxCON2<15>) = 1, the Fault inputs operate in the Inactive mode (see [Figure 3-20](#)). If a Fault input goes into an active ('0') mode, the OCFLT_x bits (OCxCON1<6:4>) are set, and the OC_x module will remain in the Fault condition until:

- The Fault input goes into an inactive mode.
- The OCFLT_x bits (OCxCON1<6:4>) are cleared in software.
- A new timer cycle is started (timer goes to 0000h).

3.3.6.2 Cycle-by-Cycle Mode

When the FLTMD bit (OCxCON2<15>) = 0, the Fault inputs operate in the Cycle-by-Cycle mode (see [Figure 3-21](#)). If a Fault input goes into an active ('0') mode, the OCFLT_x bits (OCxCON1<6:4>) are set and the OC_x module will remain in the Fault condition until:

- The Fault input goes into an inactive mode.
- A new timer cycle is started (timer goes to 0x0000).

dsPIC33/PIC24 Family Reference Manual

Figure 3-20: Fault Input Pin Timing, Inactive Mode

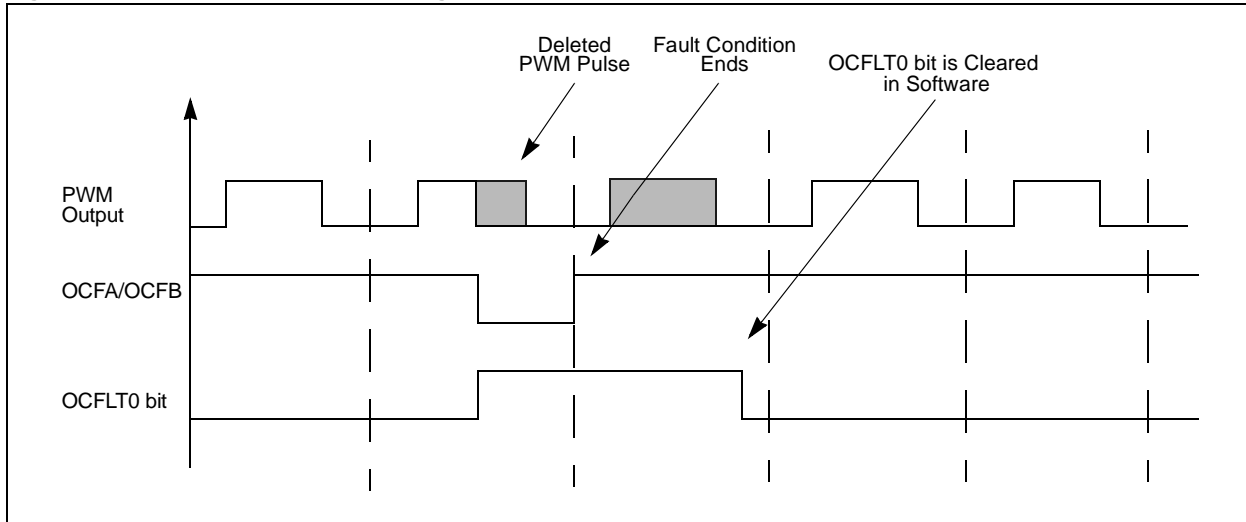
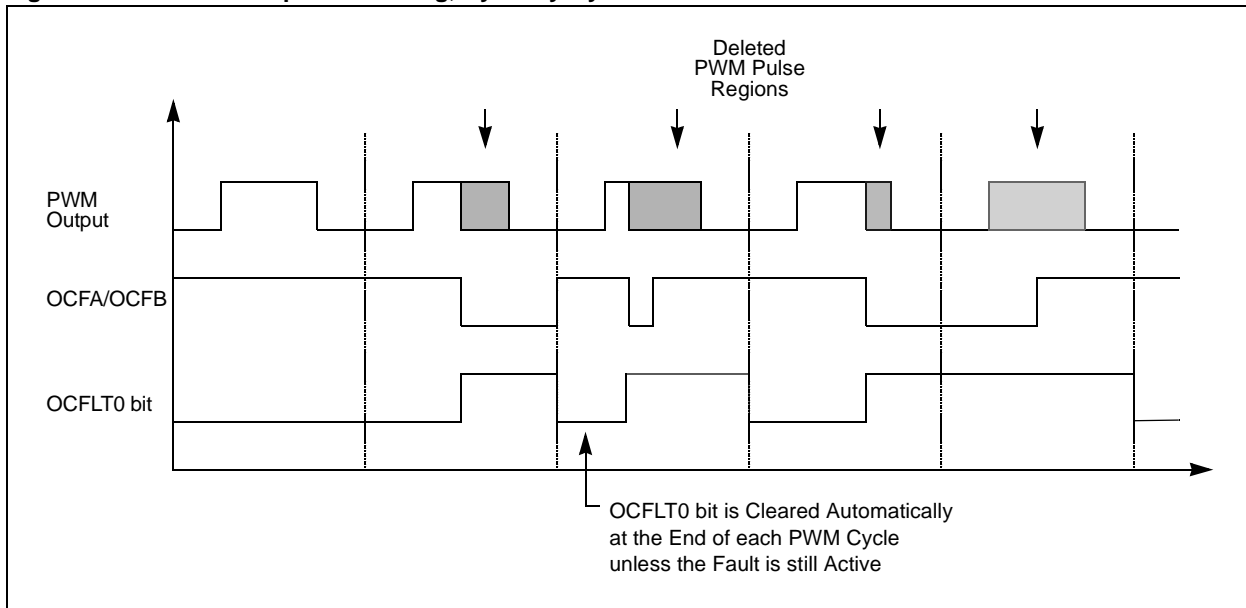

Figure 3-21: Fault Input Pin Timing, Cycle-by-Cycle Mode



Output Compare with Dedicated Timer

3.3.7 SYNCHRONOUS OPERATION

The synchronous operation of the timer is enabled when the OCTRIG bit ($OCxCON2<7>$) = 0. In synchronous operation, the TRIGSTAT bit ($OCxCON2<6>$) has no function. The timer can be synchronized with the other modules using the synchronization/trigger inputs (see [Register 2-2](#)). Whenever the selected module receives a synchronization signal, the timer will roll over to 0x0000 on the next positive edge of the selected clock.

3.3.8 USE OF THE MODULE TIMER IN A SYNCHRONIZED APPLICATION

[Figure 3-22](#) shows the connections for synchronization and [Figure 3-23](#) shows the timing for multiple modules being synchronized. The OC2 module is being synchronized to the OC1 module. The synchronization signal from OC1 is selected for synchronization by both OC1 and OC2 using the SYNCSEL<4:0> bits ($OCxCON2<4:0>$). The OC1RS register now becomes the Period register for both OC1 and OC2.

When the OC1RS register matches the OC1 timer value, the OC1 module produces the synchronization signal. This causes the timers in both OC1 and OC2 to go to zero on the next positive clock edge.

Note: Synchronized modules should select the same clock source to ensure proper operation.

Figure 3-22: Synchronous Operation Integration (TRIGEN = 0)

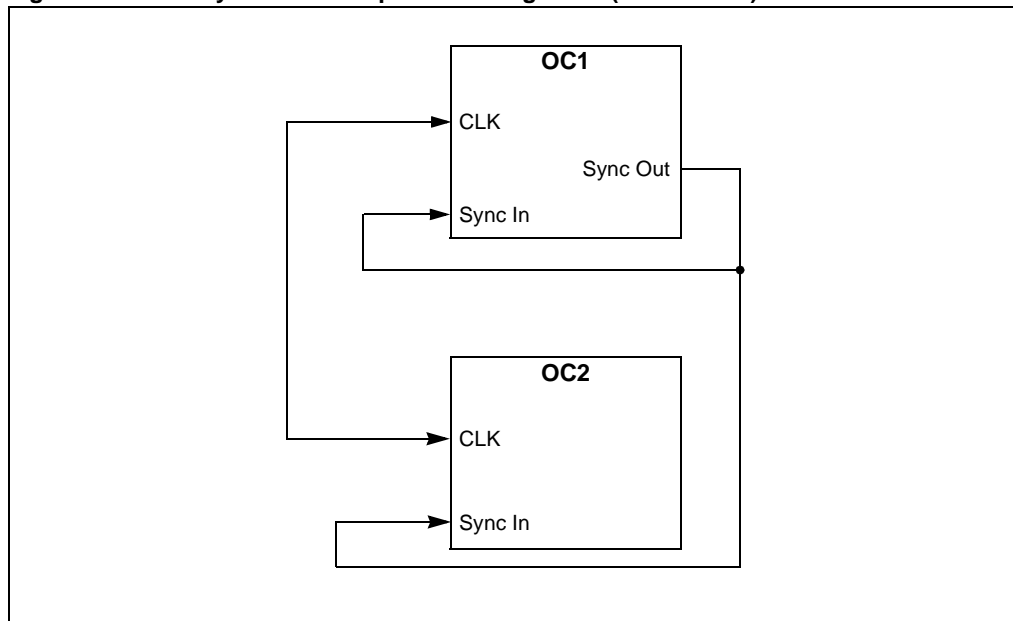

dsPIC33/PIC24 Family Reference Manual

Figure 3-23: Synchronous Operation

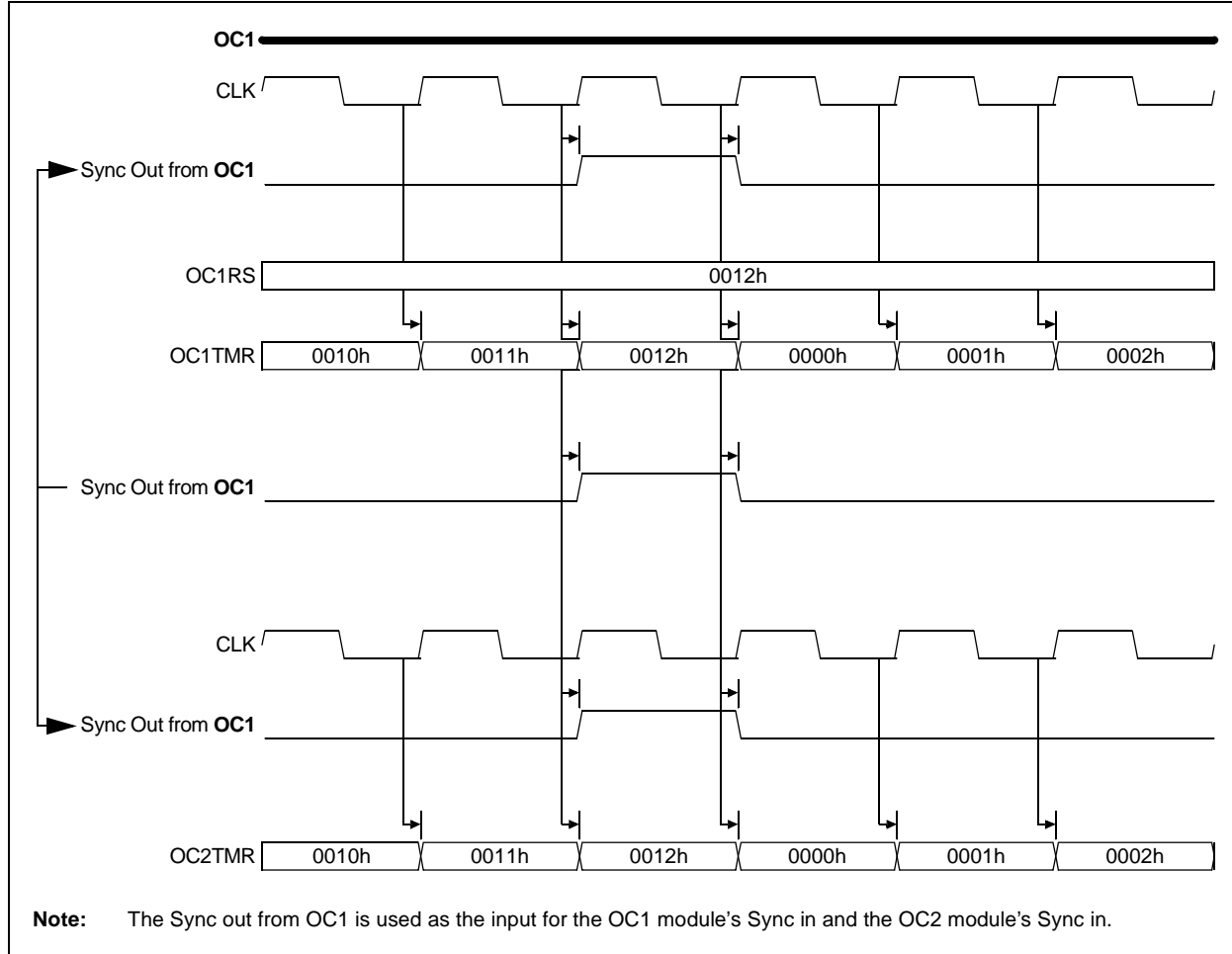

When initializing the synchronized modules, the module being used as the source of synchronization should be enabled last. As shown in [Figure 3-23](#), OC2 should be initialized first and OC1 should be initialized last. This ensures that the timers of all synchronized modules are maintained in a Reset condition until the last module is initialized.

3.3.9 TRIGGER OPERATION

Trigger operation of the timer is enabled when the OCTRIG bit ($OCxCON2<7>$) = 1. When configured for trigger operation, the module timer is held in Reset until a trigger event occurs. After the trigger event occurs, the timer begins to count. The trigger source is selected by the SYNCSELx bits.

3.3.10 OCxCON2 TRIGGER FUNCTION

The TRIGSTAT bit ($OCxCON2<6>$) holds the timer in Reset or releases it to count. It controls the timer in the following manner:

- TRIGSTAT = 0
 - Timer is held in Reset
- TRIGSTAT = 1
 - Timer is released from Reset
 - Timer increments on every positive clock

There are two types of trigger conditions when operating in a Trigger mode:

- Hardware/software, TRIGSTAT bit is set
- Software only, TRIGSTAT bit is set

In both cases, the trigger is always cleared in software.

Output Compare with Dedicated Timer

3.3.10.1 Hardware/Software TRIGSTAT Set

The TRIGSTAT bit (OCxCON2<6>) can be set by hardware or software when:

- The SYNCSELx bits (OCxCON2<4:0>) are not equal to '0b00000' (see [Section 3.3.12 "Illegal Settings"](#))

When the module is enabled for a triggered response, the timer would be held in a cleared state. It remains in this cleared state until a trigger event occurs, which sets the TRIGSTAT bit. Additionally, the timer can be released from Reset by writing to the TRIGSTAT bit and setting it.

3.3.10.2 Software Only TRIGSTAT Set

The TRIGSTAT bit can be set only by software when the SYNCSEL<4:0> bits = 0b00000.

3.3.11 CLEARING TRIGSTAT BIT

The TRIGSTAT bit can only be cleared in software by writing a '0' to it. When the TRIGSTAT bit is cleared in software, the timer is reset to 0x0000 on the next timer clock's rising edge and is ready for another trigger.

3.3.12 ILLEGAL SETTINGS

It is illegal for the module to select itself as a trigger source. Therefore, two possible values of the SYNCSEL<4:0> bits in Trigger mode are not allowed:

- SYNCSEL<4:0> = 0x1F
- SYNCSEL<4:0> = N, where N is the second setting that selects the same module (see [Register 2-2](#))

Note: The TRIGSTAT bit cannot be changed in software when operating in One-Shot mode (see [Section 3.3.13.2 "One-Shot Functionality"](#)).

The trigger source will be synchronized to the OCx clock. There should be measures to prevent these illegal conditions in the user software.

A Sync/Trigger with Timer module occurs when the corresponding TMRx register value matches with the PRx register. In Trigger mode, the OCxTMR register is held in Reset and starts counting after a match between the TMRx and PRx register occurs. In Synchronization mode, the OCxTMR and TMRx registers will count together after a match between the TMRx and PRx registers occurs.

A Sync/Trigger with an Input Capture (IC) module occurs when a capture event occurs and an IC interrupt is generated. In Trigger mode, the OCxTMR is held in Reset and starts counting after the IC interrupt is generated. In Synchronization mode, the OCxTMR and ICxTMR registers will count together after the interrupt occurs.

A Sync/Trigger between the two OC modules occurs when the OCxTMR value of the triggering OC module matches with its period value. In Trigger mode, the OCxTMR register is held in Reset and starts counting after an OC interrupt is generated for the triggering OC module. In Synchronization mode, both OCxTMR registers will count together after the interrupt occurs.

A Sync/Trigger with a comparator module occurs when the comparator module is enabled and the compare event occurs. In Trigger mode, the OCxTMR register will be held in Reset until the comparator compare event occurs and starts counting after the compare event. In Synchronization mode, the OCxTMR register will be reset and does not count as there is no comparator timer to synchronize.

A Sync/Trigger with an Analog-to-Digital Controller (ADC) module occurs when the ADC generates an interrupt after a successful conversion. In Trigger mode, the OCxTMR register will be held in Reset until the ADC interrupt occurs and starts counting after the interrupt event. In Synchronization mode, the OCxTMR register will be reset and does not count as there is no ADC timer to synchronize.

dsPIC33/PIC24 Family Reference Manual

3.3.13 USE OF THE OCx MODULE IN A TRIGGERED APPLICATION

Figure 3-24 shows a typical application of the module timer in a triggered application. In this application, a trigger event can be generated by another OC module, timer module, IC module, analog comparator or other peripheral function. Refer to the specific device data sheet for a list of trigger sources.

Note: When OCx is switched off, it sends a trigger out signal. If any other module is using OCx as a trigger source, it must disable the Trigger mode before switching off the OCx module.

3.3.13.1 Initialization of the OCx Module in a Triggered Application

The user misses any trigger event that occurs before the OCx module is initialized. Therefore, to avoid missing a trigger, the OCx module is enabled before the trigger source.

Figure 3-24: Trigger Operation Integration (TRIGEN = 1)

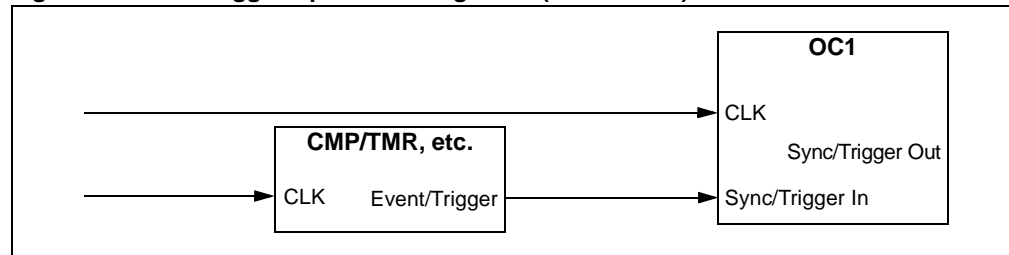

3.3.13.2 One-Shot Functionality

While operating as a trigger, the timer can operate in One-Shot mode. This produces one pulse for every trigger. The One-Shot mode is enabled by setting the TRIGMODE bit (OCxCON1<3>). In One-Shot mode, the timer remains in Reset until a trigger event occurs. This event sets the TRIGSTAT bit and the timer begins to count. When the timer rolls over to 0000h, the TRIGSTAT bit will be cleared by hardware if the TRIGMODE bit = 1. This holds the timer in Reset until the next trigger event, creating a one-shot timer.

Output Compare with Dedicated Timer

3.4 Cascade Mode

When 16-bit timers are not enough, the OCx modules can be grouped in pairs to cascade them into 32-bit timers (see [Figure 3-25](#)). They are grouped as odd and even pairs (1-2, 3-4, 5-6, etc.). When cascading, the odd OCx module forms the Least Significant 16 bits of the timer/compare and the even module forms the Most Significant 16 bits. The OCx pin of the even module is the output of the cascaded timers.

Note: When OCx is configured for PWM Cascade mode, the Even Duty Cycle register should contain a non-zero value.

Figure 3-25: Cascade Operation

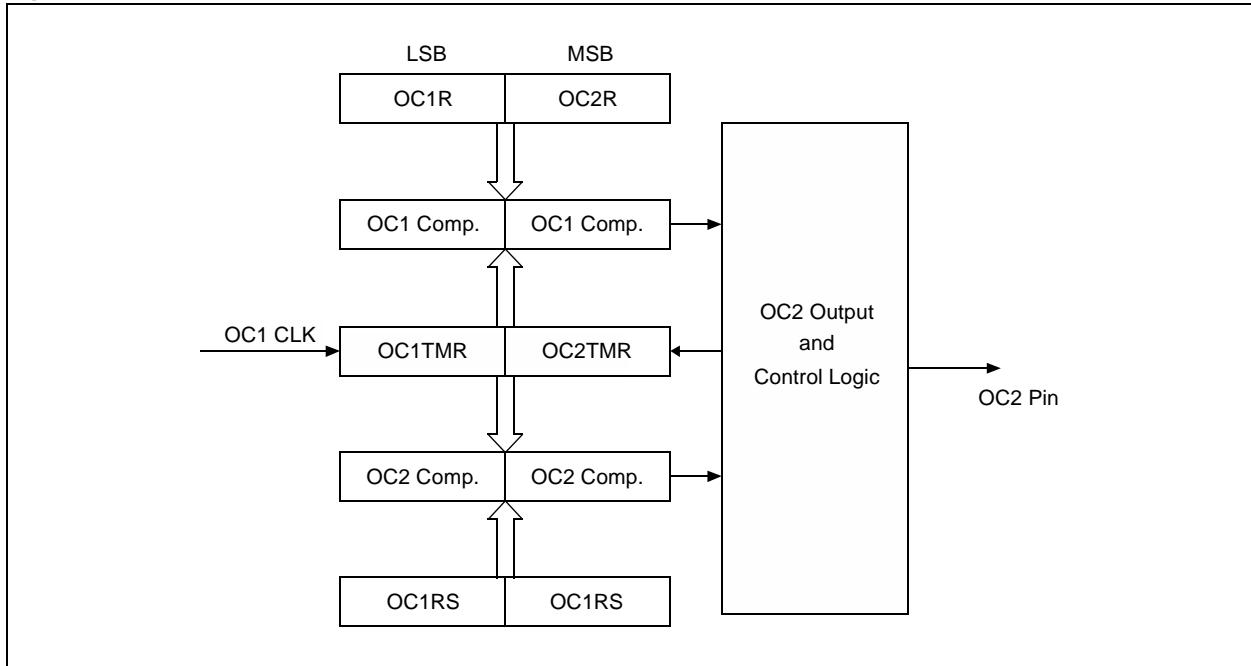

3.5 Setting Up Modules for Cascade

In this section, read OC1 as the odd OC module and OC2 as the even OC module.

The odd OC module is set up as follows:

- OC32 bit (OC1CON2<8>) = 1
- OCTRIG bit (OC1CON2<7>) can either be '1' or '0' as the timer can either be synchronized or triggered
- OCTRIS bit (OC1CON2<5>) = 1 (since the OC1 pin is not used, the output should be tri-stated)

The even OC module is set up as follows:

- OC32 bit (OC2CON1<8>) = 1
- OCTRIG bit (OC2CON2<7>) = 0 (even the timer must be operated in Synchronized mode when cascaded)
- OCTRIS bit (OC2CON2<5>) = 0 (since OC2 will be used, the output should be enabled)

3.5.1 INITIALIZATION OF THE MODULES IN A CASCADE APPLICATION

When initializing cascaded modules, the even module should be initialized first and the odd module should be initialized last. [Example 3-5](#) shows the example code for the Output Compare module in Cascade mode.

dsPIC33/PIC24 Family Reference Manual

3.5.2 TIMER CLOCK SELECTION

The timer clock should be selected before the module is enabled and should not be changed during the operation. The waveform for the cascade operation is shown in [Figure 3-26](#).

Note: The even and odd OC modules must have the same clock.

Figure 3-26: Cascade Operation in Dual Compare Mode

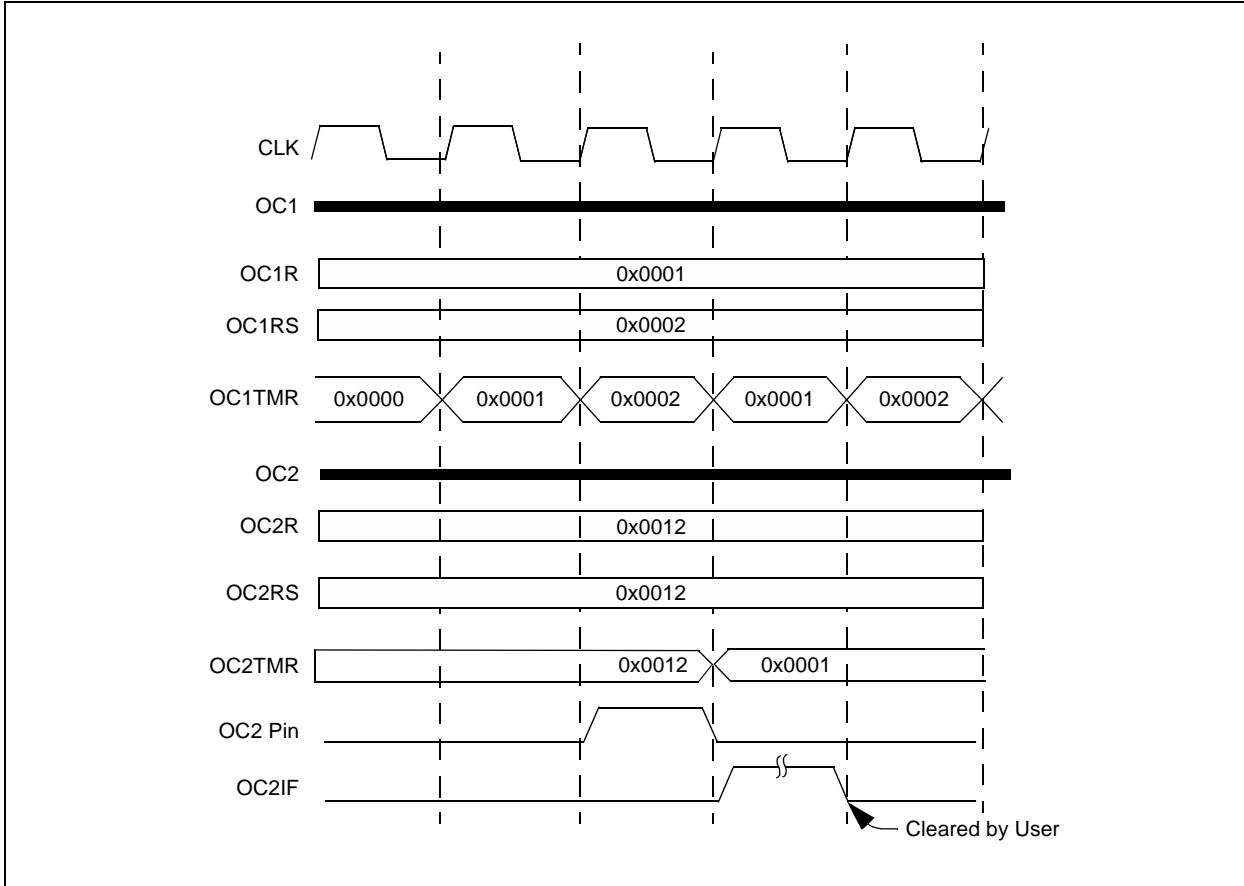

3.5.3 CASCADE OPERATION WITH THE ODD OC MODULE TRIGGERED

When the two modules are cascaded to form a 32-bit timer, the timer can be triggered by setting the odd module, OCTRIG bit (OCxCON2 <7>) = 1. The odd module remains in Reset until a trigger event occurs. Once a trigger event occurs, the odd and even modules count as usual.

3.5.4 SYNCHRONIZING MULTIPLE CASCADED MODULE PAIRS

The following examples show that multiple 32-bit pairs can be synchronized:

- To synchronize the OC3 + OC4 pair with the OC1 + OC2 pair:
 - OC1 and OC2 are set up as defined in [Section 3.5 “Setting Up Modules for Cascade”](#).
 - OC3 and OC4 are set up in the same way, but the SYNCSEL bit = 1 (synchronization out from OC1); this allows the sync out from OC1 to hold OC3 in sync.

Output Compare with Dedicated Timer

Example 3-5: Output Compare in Cascade Mode

```
OC1CON1 = 0;           /* It is a good practice to clear off the control bits initially */
OC1CON2 = 0;
OC2CON1 = 0;
OC2CON2 = 0;

OC1CON1bits.OCTSEL = 0x07; /* This selects the peripheral clock as the clock input to the OC
                             module */
OC2CON1bits.OCTSEL = 0x07;

OC1R = 0x1000;         /* Determines the On-Time */
OC2R = 0x0002;         /* Determines the On-Time */

OC1RS = 0x2000;        /* Determines the Period */
OC2RS = 0x0003;        /* Determines the Period */

OC1CON2bits.SYNCSEL = 0x1F;
OC2CON2bits.SYNCSEL = 0x1F;

OC1CON2bits.OCTRIS = 1; /* Odd module's output is not required */

/* Even module must be enabled first */
/* Odd module must be enabled last */

OC2CON2bits.OC32 = 1;
OC1CON2bits.OC32 = 1;

OC2CON1bits.OCM = 6;    /* This selects the Edge Aligned PWM mode */
OC1CON1bits.OCM = 6;    /* This starts the cascaded timer */
```

3.5.5 PWM IN CASCADING MODE

A PWM pulse can be generated by cascading two OC modules. Cascading can be used if the compare values are more than 16 bits. A proper PWM pulse is not generated when the compare values are 16-bit or less and the Cascade mode is selected. If the compare values are 16-bit or less, the OC module has to configure for 16-bit operation.

Example 3-6: PWM In Cascade Mode

```
OC1R = 1000;           /* Compare value */
OC2R = 2;              /* Compare value */
OC1RS = 2000;          /* Period */
OC2RS = 3;             /* Period */
```

In [Example 3-6](#), the compare value for the OC cascaded timer is 21000 (OC2R-OC1R cascaded) and the period is 32000 (OC2RS-OC1RS cascaded). For a match between OC2TMR-OC1TMR (cascaded) and OC2R-OC1R (cascaded), the OCx pin goes high. The pin is set low for a match of OC2RS-OC1RS (cascaded). The OC2TMR always resets for a match of OC2RS and the OC1TMR counts up to 0xFFFF.

dsPIC33/PIC24 Family Reference Manual

The following are the cases when the compare value is 16 bits or less:

- If OC2RS = 0, then in the first match between OC2TMR-OC1TMR (cascaded) and OC2R-OC1R (cascaded), the OCx pin goes high. Since OC2RS, which determines the period is '0', both the OC2TMR and OC1TMR keep incrementing and reset on overflow. Therefore, the output remains high and no PWM pulse is obtained.
- If OC2R = 0, then in the first match between OC2TMR-OC1TMR (cascaded) and OC2R-OC1R (cascaded) – or OC1R, since OC2R = 0, the OCx pin goes high. The OC2TMR increments by 1 when the OC1TMR reaches 0xFFFF. The OC2TMR clears for a match with OC2RS. The pin remains high and no PWM pulse is obtained.
- If OC2R = 0 and OC2RS = 0, then in the first match between OC2TMR-OC1TMR (cascaded) and OC2R-OC1R (cascaded) – or OC1R and OC1TMR, since OC2R, OC2TMR = 0, the OCx pin goes high. The OC1TMR clears for the first match to OC1RS and OC2TMR increments by 1 for this match, and both the timers keep incrementing until they reach 0xFFFF. The pin remains high and no PWM pulse is obtained.

3.5.6 EFFECTS OF DCB<1:0> SETTINGS

The DCB<1:0> bits (OCxCON2 <10:9>) setting can be used to achieve a finer resolution of a duty cycle. If the DCBx bits = 0b00, then there would be no effect of the DCBx bits but for the settings, 0b01, 0b10 and 0b11, and the second edge of the pulse is delayed until the rising edge of the P2, P3 and P4 clocks, respectively. Since these quadrature clocks may not have a 50% duty cycle, selecting between adjacent quadrature clocks may not yield a 25% difference, but selecting between the P1 and P3 clocks will yield a 50% difference (see [Figure 3-27](#)).

Note: A duty cycle setting of 0 (without DCBx bits) will not have any effect because of the DCBx bits. The DCBx bits will have their effect only if there is a pulse.

A prescaler will not scale the effects of the DCB<1:0> bits; that is, even if the prescaler is used to divide the clock fed to the OCx module, the effect of the DCB<1:0> bits will be as if no prescaler is used.

Figure 3-27: Falling Edge Control Using DCB<1:0> (OCxCON2<10:9>)

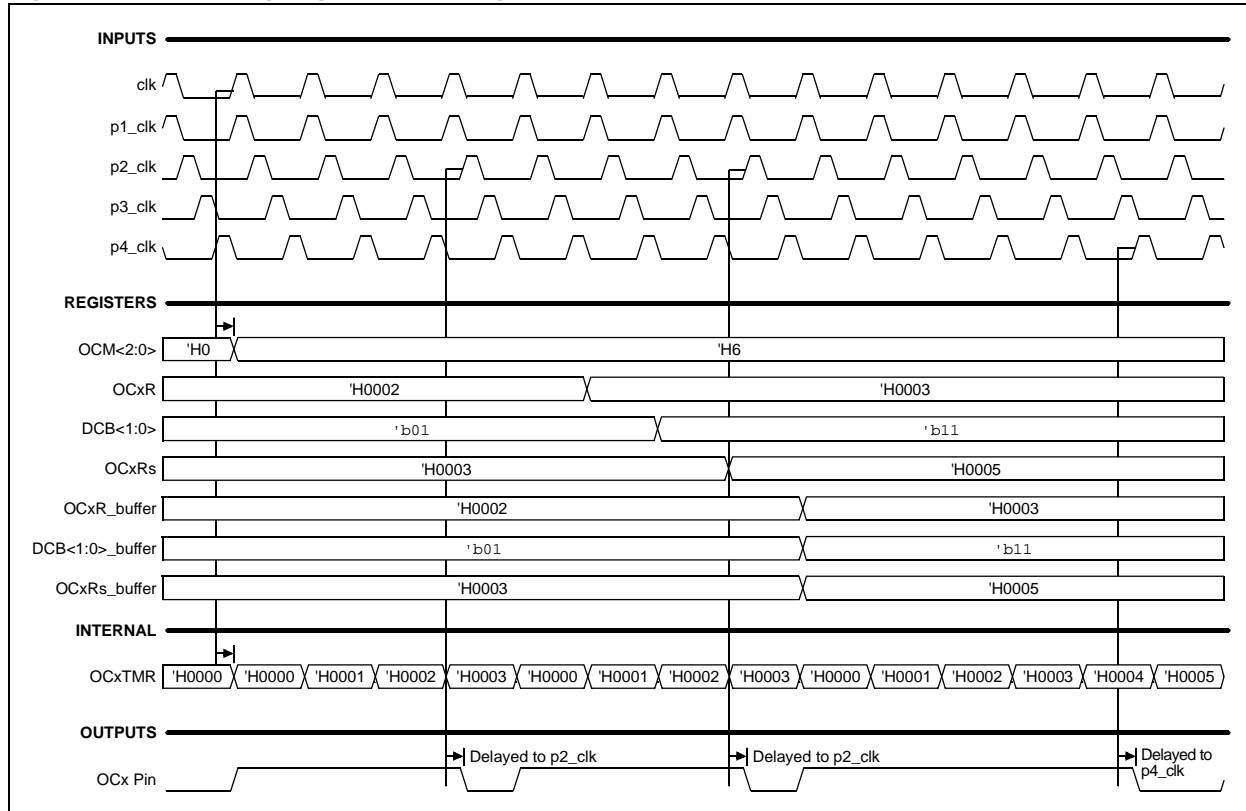

Output Compare with Dedicated Timer

4.0 OUTPUT COMPARE OPERATION WITH DMA

Some Output Compare with Dedicated Timer family devices include a Direct Memory Access (DMA) module, which allows data transfer from data memory to the OCx module without CPU intervention.

The DMA channel must be initialized with the following:

- Initialize the DMAx Channel Peripheral Address (DMAxPAD) register to the address of the Output Compare x (OCxR) register or the Output Compare x Secondary (OCxRS) register.
- Set the Transfer Direction (DIR) bit in the DMAx Control (DMAxCON<13>) register. In this condition, data is read from the dual port DMA memory and written to the peripheral's Special Function Register (SFR).
- The DMA Request Source Selection (IRQSEL<7:0>) bits in the DMAx Request (DMAxREQ<7:0>) register must select the DMA transfer request source.

Example 4-1 provides sample code that modulates the PWM duty cycle without CPU intervention. The duty cycle values stored in an array are transferred to the OCxRS register on every timer interrupt.

Note: The DMA module is not available on all devices. For more information, refer to the specific device data sheet.

Example 4-1: Code to Modulate the PWM Duty Cycle Without CPU Intervention

```
//Define Buffer in RAM as global variable:
    unsigned int BufferA[256] __attribute__((space(xmemory)));

//initialize buffer with duty cycle values
    int i;
    for(i=0;i<256;i++)
        BufferA[i]=i;
//Initialize Output Compare Module in PWM mode
    OC1CON1bits.OCM = 0b000;           // Disable Output Compare Module
    OC1R=100;                          // Write the duty cycle for the PWM pulse
    OC1RS=255;                          // Write the PWM frequency
    OC1CON1bits.OCTSEL = 0;             // Select Timer2 as output compare time base
    OC1CON1bits.OCM = 0b110;           // Select the Output Compare mode
    OC1CON2bits.SYNCSEL=31;            // OC2RS compare event is used for synchronization

// Initialize Timer2
    T2CONbits.TON = 0;                 // Disable Timer
    T2CONbits.TCS = 0;                 // Select internal instruction cycle clock
    T2CONbits.TGATE = 0;               // Disable Gated Timer mode
    T2CONbits.TCKPS = 0b00;            // Select 1:1 Prescaler
    TMR2 = 0x00;                       // Clear timer register
    PR2 = 500;                         // Load the period value

// Set up and Enable DMA Channel
    DMA0CONbits.AMODE = 0b00;          // Register indirect with post increment
    DMA0CONbits.MODE = 0b00;           // Continuous, Ping-Pong mode Disabled
    DMA0CONbits.DIR = 1;                // Peripheral to RAM
    DMA0PAD = (int)&OC1R;                // Address of the output compare register
    DMA0REQ = 7;                        // Select Timer2 interrupt as DMA request source
    DMA0CNT = 255;                      // Number of words to buffer.

    DMA0STAH = (unsigned int)&BufferA;
    DMA0STAL = (unsigned int)&BufferA;

    IFS0bits.DMA0IF = 0;                // Clear the DMA interrupt flag
    IEC0bits.DMA0IE = 1;                // Enable DMA interrupt
    DMA0CONbits.CHEN = 1;                // Enable DMA channel

// Enable Timer
    T2CONbits.TON = 1;                  // Start Timer

//Set up DMA Interrupt Handler:

    void __attribute__((__interrupt__,__no_auto_psv)) _DMA0Interrupt(void)
    {
        // Process the captured values
        IFS0bits.DMA0IF = 0;            // Clear the DMA0 Interrupt Flag
    }
}
```

dsPIC33/PIC24 Family Reference Manual

5.0 OUTPUT COMPARE OPERATION IN POWER-SAVING STATES

5.1 Output Compare Operation in Sleep Mode

When the device enters Sleep mode, the system clock is disabled. During Sleep, the Output Compare x channel drives the pin to the same active state as it was driven prior to entering the Sleep state. The OCx module then halts at this state.

For example, if the pin was high and the CPU enters the Sleep state, the pin stays high. Likewise, if the pin was low and the CPU enters the Sleep state, the pin stays low. In both cases, when the device awakes, the OCx module resumes operation.

5.2 Sleep with PWM Fault Mode

When the OCx module is in PWM Fault mode, the asynchronous portions of the Fault circuit remain active. If a Fault is detected, the output of OCx is determined by the FLTOUT and OCTRIS bits setting in the OCxCON2 register. The FLTOUT bit will be set. An interrupt will not be generated at a Fault occurrence. However, the interrupt will be queued and will occur at the time the part wakes up.

5.3 Output Compare Operation in Idle Mode

When the device enters Idle mode, the system clock sources remain functional and the CPU stops executing code. The Output Compare x Stop in Idle Mode Control (OCSIDL) bit in the (OCxCON1<13>) register selects if the output capture module stops in Idle mode or continues operation in Idle mode.

- If the bit, OCSIDL = 1, then the module discontinues the operation in Idle mode. The module performs the same procedures when stopped in Idle mode (OCSIDL = 1) as it does for Sleep mode.
- If the bit, OCSIDL = 0, then the Output Compare x channel(s) operate during the CPU Idle mode. Furthermore, the time base must be enabled with the respective TSIDL bit set to a logic '0'; if internal, the timer is used as the clock source.

Note: The external Fault pins, if enabled for use, continue to control the associated OCx output pins while the device is in Sleep mode or in Idle mode.

5.4 Doze Mode

Output Compare operation in Doze mode is the same as in normal mode. When the device enters Doze mode, the system clock sources remain functional and the CPU may run at a slower clock rate.

5.5 Selective Peripheral Module Control

The Peripheral Module Disable x (PMDx) registers provide a method to disable the OCx module by stopping all the clock sources supplied to it. When the module is disabled through the appropriate PMDx control bit, it is in a minimum power consumption state. The control and status registers associated with the module will be disabled. Therefore, a write to these registers will have no effect, and the read values will be invalid and return to zero.

Output Compare with Dedicated Timer

6.0 I/O PIN CONTROL

When the OCx module is enabled, the Input/Output (I/O) pin direction is controlled by the Output Compare x module. The Output Compare x module returns the I/O pin control back to the appropriate LATx and TRISx control bits when it is disabled. When the Simple PWM with Fault Protection Input mode is enabled, the OCFA/OCFB Fault pins must be configured as inputs by setting the respective TRISx bits. Enabling this special PWM mode does not configure the OCFA/OCFB Fault pins as inputs.

Note: Refer to the specific device data sheet for the availability of the Output Compare x module and Fault pins.

If the PPS feature is present, the OCx module I/Os must be assigned to the required remappable pins before enabling the module.

7.0 REGISTER MAPS

A summary of the registers associated with the Output Compare with Dedicated Timer module is provided in [Table 7-1](#).

Table 7-1: Output Compare x with Dedicated Timer Register Map

File Name	Bit 15	Bit 14	Bit 13	Bit 12	Bit 11	Bit 10	Bit 9	Bit 8	Bit 7	Bit 6	Bit 5	Bit 4	Bit 3	Bit 2	Bit 1	Bit 0	All Resets
OCxCON1	—	—	OCSIDL	OCTSEL2	OCTSEL1	OCTSEL0	ENFLT2/C	ENFLT1/B	ENFLT0/A	OCFLT2/C	OCFLT1/B	OCFLT0/A	TRIGMODE	OCM2	OCM1	OCM0	0000
OCxCON2	FLTMD	FLTOUT	FLTTRIEN	OCINV	—	DCB1	DCB0	OC32	OCTRIG	TRIGSTAT	OCTRIS	SYNCSEL4	SYNCSEL3	SYNCSEL2	SYNCSEL1	SYNCSEL0	0000
OCxRS	Output Compare x Secondary Register																0000
OCxR	Output Compare x Register																0000
OCxTMR	Output Compare x Timer Value Register																xxxx

Legend: — = unimplemented, read as '0'. Reset values are shown in hexadecimal.

Note: For details on the Output Compare with Dedicated Timer map, refer to the specific device data sheet.

Output Compare with Dedicated Timer

8.0 DESIGN TIPS

Question 1: *The Output Compare x pin stops functioning even when the OCSIDL bit is not set. Why?*

Answer: This is most likely to occur when the TSIDL (TxCON<13>) bit of the associated timer source is set if it is used as the clock source. Therefore, it is the timer that actually goes into Idle mode when the PWRSAV instruction is executed and the clock is not generated.

Question 2: *Can I cascade OC2 and OC3?*

Answer: No; cascading can be done only in pairs of OC1-OC2, OC3-OC4, etc., and OC9 cannot be paired.

Question 3: *My device has PPS and I have mapped the OCx pins to the remappable pins. Still, it doesn't work. Why?*

Answer: Verify if the required values are actually written to the appropriate registers. Writing into PPS registers might require unlocking and locking sequences.

dsPIC33/PIC24 Family Reference Manual

9.0 RELATED APPLICATION NOTES

This section lists application notes that are related to this section of the manual. These application notes may not be written specifically for the dsPIC33/PIC24F device families, but the concepts are pertinent and could be used with modification and possible limitations. The current application notes related to the Output Compare with Dedicated Timer module are:

Title

Application Note #

No related application notes at this time.

<p>Note: Please visit the Microchip web site (www.microchip.com) for additional application notes and code examples for the dsPIC33/PIC24 families of devices.</p>
--

Output Compare with Dedicated Timer

10.0 REVISION HISTORY

Revision A (March 2014)

This is the initial released version of this document.

dsPIC33/PIC24 Family Reference Manual

NOTES:

Note the following details of the code protection feature on Microchip devices:

- Microchip products meet the specification contained in their particular Microchip Data Sheet.
- Microchip believes that its family of products is one of the most secure families of its kind on the market today, when used in the intended manner and under normal conditions.
- There are dishonest and possibly illegal methods used to breach the code protection feature. All of these methods, to our knowledge, require using the Microchip products in a manner outside the operating specifications contained in Microchip's Data Sheets. Most likely, the person doing so is engaged in theft of intellectual property.
- Microchip is willing to work with the customer who is concerned about the integrity of their code.
- Neither Microchip nor any other semiconductor manufacturer can guarantee the security of their code. Code protection does not mean that we are guaranteeing the product as “unbreakable.”

Code protection is constantly evolving. We at Microchip are committed to continuously improving the code protection features of our products. Attempts to break Microchip's code protection feature may be a violation of the Digital Millennium Copyright Act. If such acts allow unauthorized access to your software or other copyrighted work, you may have a right to sue for relief under that Act.

Information contained in this publication regarding device applications and the like is provided only for your convenience and may be superseded by updates. It is your responsibility to ensure that your application meets with your specifications. MICROCHIP MAKES NO REPRESENTATIONS OR WARRANTIES OF ANY KIND WHETHER EXPRESS OR IMPLIED, WRITTEN OR ORAL, STATUTORY OR OTHERWISE, RELATED TO THE INFORMATION, INCLUDING BUT NOT LIMITED TO ITS CONDITION, QUALITY, PERFORMANCE, MERCHANTABILITY OR FITNESS FOR PURPOSE. Microchip disclaims all liability arising from this information and its use. Use of Microchip devices in life support and/or safety applications is entirely at the buyer's risk, and the buyer agrees to defend, indemnify and hold harmless Microchip from any and all damages, claims, suits, or expenses resulting from such use. No licenses are conveyed, implicitly or otherwise, under any Microchip intellectual property rights.

Trademarks

The Microchip name and logo, the Microchip logo, dsPIC, FlashFlex, KEELOQ, KEELOQ logo, MPLAB, PIC, PICmicro, PICSTART, PIC³² logo, rPIC, SST, SST Logo, SuperFlash and UNI/O are registered trademarks of Microchip Technology Incorporated in the U.S.A. and other countries.

FilterLab, Hampshire, HI-TECH C, Linear Active Thermistor, MTP, SEEVAL and The Embedded Control Solutions Company are registered trademarks of Microchip Technology Incorporated in the U.S.A.

Silicon Storage Technology is a registered trademark of Microchip Technology Inc. in other countries.

Analog-for-the-Digital Age, Application Maestro, BodyCom, chipKIT, chipKIT logo, CodeGuard, dsPICDEM, dsPICDEM.net, dsPICworks, dsSPEAK, ECAN, ECONOMONITOR, FanSense, HI-TIDE, In-Circuit Serial Programming, ICSP, Mindi, MiWi, MPASM, MPF, MPLAB Certified logo, MPLIB, MPLINK, mTouch, Omniclient Code Generation, PICC, PICC-18, PICDEM, PICDEM.net, PICkit, PICtail, REAL ICE, rLAB, Select Mode, SQI, Serial Quad I/O, Total Endurance, TSHARC, UniWinDriver, WiperLock, ZENA and Z-Scale are trademarks of Microchip Technology Incorporated in the U.S.A. and other countries.

SQTP is a service mark of Microchip Technology Incorporated in the U.S.A.

GestIC and ULPP are registered trademarks of Microchip Technology Germany II GmbH & Co. KG, a subsidiary of Microchip Technology Inc., in other countries.

All other trademarks mentioned herein are property of their respective companies.

© 2014, Microchip Technology Incorporated, Printed in the U.S.A., All Rights Reserved.

 Printed on recycled paper.

ISBN: 978-1-62077-958-3

Microchip received ISO/TS-16949:2009 certification for its worldwide headquarters, design and wafer fabrication facilities in Chandler and Tempe, Arizona; Gresham, Oregon and design centers in California and India. The Company's quality system processes and procedures are for its PIC[®] MCUs and dsPIC[®] DSCs, KEELOQ[®] code hopping devices, Serial EEPROMs, microperipherals, nonvolatile memory and analog products. In addition, Microchip's quality system for the design and manufacture of development systems is ISO 9001:2000 certified.

QUALITY MANAGEMENT SYSTEM
CERTIFIED BY DNV
== ISO/TS 16949 ==



MICROCHIP

Worldwide Sales and Service

AMERICAS

Corporate Office
2355 West Chandler Blvd.
Chandler, AZ 85224-6199
Tel: 480-792-7200
Fax: 480-792-7277
Technical Support:
<http://www.microchip.com/support>
Web Address:
www.microchip.com

Atlanta
Duluth, GA
Tel: 678-957-9614
Fax: 678-957-1455

Austin, TX
Tel: 512-257-3370

Boston
Westborough, MA
Tel: 774-760-0087
Fax: 774-760-0088

Chicago
Itasca, IL
Tel: 630-285-0071
Fax: 630-285-0075

Cleveland
Independence, OH
Tel: 216-447-0464
Fax: 216-447-0643

Dallas
Addison, TX
Tel: 972-818-7423
Fax: 972-818-2924

Detroit
Novi, MI
Tel: 248-848-4000

Houston, TX
Tel: 281-894-5983

Indianapolis
Noblesville, IN
Tel: 317-773-8323
Fax: 317-773-5453

Los Angeles
Mission Viejo, CA
Tel: 949-462-9523
Fax: 949-462-9608

New York, NY
Tel: 631-435-6000

San Jose, CA
Tel: 408-735-9110

Canada - Toronto
Tel: 905-673-0699
Fax: 905-673-6509

ASIA/PACIFIC

Asia Pacific Office
Suites 3707-14, 37th Floor
Tower 6, The Gateway
Harbour City, Kowloon
Hong Kong
Tel: 852-2401-1200
Fax: 852-2401-3431

Australia - Sydney
Tel: 61-2-9868-6733
Fax: 61-2-9868-6755

China - Beijing
Tel: 86-10-8569-7000
Fax: 86-10-8528-2104

China - Chengdu
Tel: 86-28-8665-5511
Fax: 86-28-8665-7889

China - Chongqing
Tel: 86-23-8980-9588
Fax: 86-23-8980-9500

China - Hangzhou
Tel: 86-571-2819-3187
Fax: 86-571-2819-3189

China - Hong Kong SAR
Tel: 852-2943-5100
Fax: 852-2401-3431

China - Nanjing
Tel: 86-25-8473-2460
Fax: 86-25-8473-2470

China - Qingdao
Tel: 86-532-8502-7355
Fax: 86-532-8502-7205

China - Shanghai
Tel: 86-21-5407-5533
Fax: 86-21-5407-5066

China - Shenyang
Tel: 86-24-2334-2829
Fax: 86-24-2334-2393

China - Shenzhen
Tel: 86-755-8864-2200
Fax: 86-755-8203-1760

China - Wuhan
Tel: 86-27-5980-5300
Fax: 86-27-5980-5118

China - Xian
Tel: 86-29-8833-7252
Fax: 86-29-8833-7256

China - Xiamen
Tel: 86-592-2388138
Fax: 86-592-2388130

China - Zhuhai
Tel: 86-756-3210040
Fax: 86-756-3210049

ASIA/PACIFIC

India - Bangalore
Tel: 91-80-3090-4444
Fax: 91-80-3090-4123

India - New Delhi
Tel: 91-11-4160-8631
Fax: 91-11-4160-8632

India - Pune
Tel: 91-20-3019-1500

Japan - Osaka
Tel: 81-6-6152-7160
Fax: 81-6-6152-9310

Japan - Tokyo
Tel: 81-3-6880-3770
Fax: 81-3-6880-3771

Korea - Daegu
Tel: 82-53-744-4301
Fax: 82-53-744-4302

Korea - Seoul
Tel: 82-2-554-7200
Fax: 82-2-558-5932 or
82-2-558-5934

Malaysia - Kuala Lumpur
Tel: 60-3-6201-9857
Fax: 60-3-6201-9859

Malaysia - Penang
Tel: 60-4-227-8870
Fax: 60-4-227-4068

Philippines - Manila
Tel: 63-2-634-9065
Fax: 63-2-634-9069

Singapore
Tel: 65-6334-8870
Fax: 65-6334-8850

Taiwan - Hsin Chu
Tel: 886-3-5778-366
Fax: 886-3-5770-955

Taiwan - Kaohsiung
Tel: 886-7-213-7830

Taiwan - Taipei
Tel: 886-2-2508-8600
Fax: 886-2-2508-0102

Thailand - Bangkok
Tel: 66-2-694-1351
Fax: 66-2-694-1350

EUROPE

Austria - Wels
Tel: 43-7242-2244-39
Fax: 43-7242-2244-393

Denmark - Copenhagen
Tel: 45-4450-2828
Fax: 45-4485-2829

France - Paris
Tel: 33-1-69-53-63-20
Fax: 33-1-69-30-90-79

Germany - Dusseldorf
Tel: 49-2129-3766400

Germany - Munich
Tel: 49-89-627-144-0
Fax: 49-89-627-144-44

Germany - Pforzheim
Tel: 49-7231-424750

Italy - Milan
Tel: 39-0331-742611
Fax: 39-0331-466781

Italy - Venice
Tel: 39-049-7625286

Netherlands - Drunen
Tel: 31-416-690399
Fax: 31-416-690340

Poland - Warsaw
Tel: 48-22-3325737

Spain - Madrid
Tel: 34-91-708-08-90
Fax: 34-91-708-08-91

Sweden - Stockholm
Tel: 46-8-5090-4654

UK - Wokingham
Tel: 44-118-921-5800
Fax: 44-118-921-5820

10/28/13